

Manual | EN

C9900-U330

Battery pack



Table of contents

1	Notes on the documentation	5
2	For your safety.....	6
2.1	Description of safety symbols	6
2.2	Intended use	6
2.3	Fundamental safety instructions	7
2.4	Operator's obligation to exercise diligence	7
3	Product overview.....	8
3.1	Structure	8
3.2	Name plate	9
4	Commissioning.....	10
4.1	Transport and unpacking	10
4.2	Dimensions	11
4.3	Control cabinet installation	12
4.4	Connect battery pack.....	13
5	Decommissioning.....	17
6	Maintenance	19
7	Technical data.....	20
8	Appendix	21
8.1	Service and support.....	21
8.2	Approvals.....	22

1 Notes on the documentation

This description is only intended for the use of trained specialists in control and automation engineering who are familiar with the applicable national standards.

The following instructions and explanations must be followed during installation and commissioning of the components. The responsible staff must ensure that the application or use of the products described satisfy all the requirements for safety, including all the relevant laws, regulations, guidelines and standards.

Disclaimer

The documentation has been prepared with care. The products described are, however, constantly under development. For that reason the documentation is not in every case checked for consistency with performance data, standards or other characteristics. In the event that it contains technical or editorial errors, we retain the right to make alterations at any time and without warning. No claims for the modification of products that have already been supplied may be made on the basis of the data, diagrams, and descriptions in this documentation. All illustrations shown are only examples. The configurations depicted may deviate from the standard.

Trademarks

Beckhoff®, TwinCAT®, TwinCAT/BSD®, TC/BSD®, EtherCAT®, EtherCAT G®, EtherCAT G10®, EtherCAT P®, Safety over EtherCAT®, TwinSAFE®, XFC®, XTS® and XPlanar® are registered and licensed trademarks of Beckhoff Automation GmbH.

Other designations used in this publication may be trademarks whose use by third parties for their own purposes could violate the rights of the owners.

Patents

The EtherCAT Technology is covered, including but not limited to the following patent applications and patents: EP1590927, EP1789857, EP1456722, EP2137893, DE102015105702 and similar applications and registrations in several other countries.

Copyright

© Beckhoff Automation GmbH & Co. KG. Publication of this document on websites other than ours is prohibited. Offenders will be held liable for the payment of damages. All rights reserved in the event of the grant of a patent, utility model or design.

Delivery state

All the components are supplied in particular hardware and software configurations appropriate for the application. Changes to the hardware or software configuration are permitted, provided they are within the specified limits for power consumption and power loss (please refer to the respective data sheet).

Delivery conditions

In addition, the general delivery conditions of the company Beckhoff Automation GmbH & Co. KG apply.

2 For your safety

The Safety chapter first explains the safety symbols used in the documentation and their meanings. They contain fundamental safety instructions that are essential for the avoidance of personal injuries and damage to property.

Exclusion of liability

Beckhoff shall not be liable in the event of non-compliance with this documentation and thus the use of the battery packs outside the documented operating conditions.

2.1 Description of safety symbols

The following safety symbols are used in these operating instructions. In order to avoid personal injuries and damage to property, read and follow the safety and warning notices.

Warning of personal injuries:

DANGER

Disregarding the safety notice will lead to death or serious injuries.

WARNING

Disregarding the safety notice may lead to death or serious injuries.

CAUTION

Disregarding the safety notice may lead to minor injuries.

Warning of damage to property:

NOTE

Disregarding the notice may lead to damage to property.

2.2 Intended use

The battery pack is designed for DIN rail mounting in control cabinets of machine and system engineering. It serves PCs with 24 V power supply unit and integrated C9900-P209 or C9900-U209 UPS as external energy storage.

The specified limits for technical data must be adhered to.

The battery pack can be used within the documented operating conditions.

Improper use

Do not use the battery pack outside the documented operating conditions.

2.3 Fundamental safety instructions

The following safety instructions must be observed when handling the battery pack.

Application conditions

- Do not use the battery pack under extreme environmental conditions.
- Never use the battery pack in potentially explosive atmospheres.
- Provide openings in the control cabinet walls for sufficient ventilation of the control cabinet in accordance with EN 50272-2. This avoids the risk of explosion due to gas escaping from the battery packs.
- Never plug or unplug connectors during thunderstorms. There is a risk of electric shock.
- Ensure protective earthing of the battery pack.

Damage to property and impairment of functions

- Ensure that only trained specialists with a control and automation engineering background, operate the PC to which the battery pack is connected. Use by unauthorized persons can lead to damage to property.
- Extinguish the battery pack with foam halogens in case of fire or with a large amount of spray water in case of large fires.

2.4 Operator's obligation to exercise diligence

The operator must ensure that

- the products are only used as intended (see chapter 2.2 [Intended use](#) [▶ 6]).
- the products are only operated in sound condition and in working order.
- only sufficiently qualified and authorized personnel operate the PC to which the battery pack is connected.
- the personnel is instructed regularly about relevant occupational safety and environmental protection aspects, and is familiar with the operating instructions and in particular the safety instructions contained herein.
- the operating instructions are in good condition and complete, and always available for reference at the location where the products are used.

3 Product overview

The battery pack C9900-U330 serves as energy storage for PCs with 24 V power supply unit and integrated UPS and continues to supply the PC with energy in the event of a power failure. It allows backing up the data to a hard disk or flash media (e.g. SSD or CFast) and shutting down the PC properly. The battery pack is intended for external mounting in control cabinets of machine and system engineering.

The battery pack has a nominal capacity of 3.4 Ah.

The internal structure of the battery pack consists of two 12 V batteries in series connection. The VRLA-AGM technology (valve regulated lead acid absorbed glass mat technology) is applied. These are valve regulated lead-acid batteries with fiberglass mats in the separator.

3.1 Structure



Fig. 1: C9900-U330_Structure

Table 1: Key for C9900-U330 structure

No.	Component	Description
1	Name plate	Information about the equipment of the battery pack
2	Socket head screws	Screws for securing the battery pack on the DIN rail
3	5-pin terminal strip	Connecting the battery pack to the power supply unit of the PC

3.2 Name plate

The name plate provides information about the battery pack equipment.

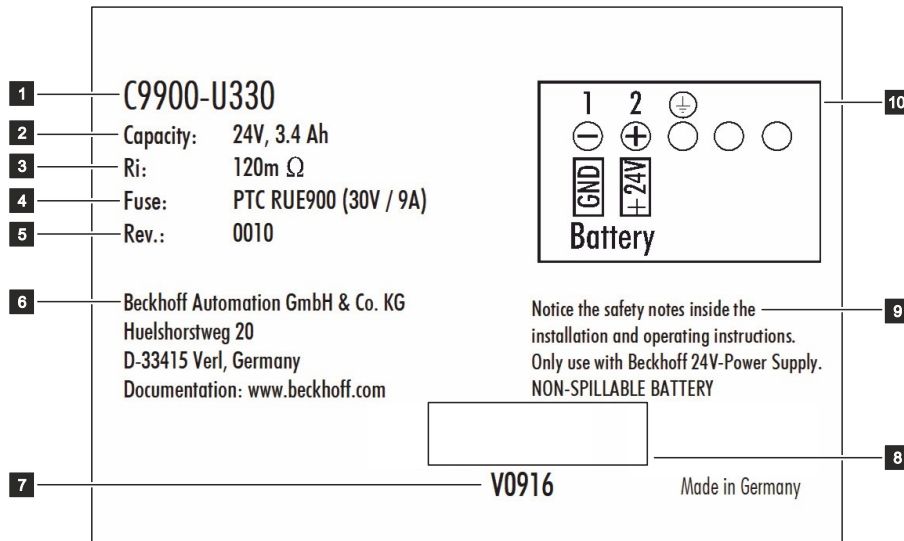



Fig. 2: C9900-U330_name plate

Table 2: Key for C9900-U330 name plate

No.	Description
1	Model
2	Nominal capacity
3	Internal resistance
4	Fuse
5	Revision
6	Address of the vendor
7	Coded production date
8	Symbols Note: here are the symbols applicable to the battery pack such as CE, EAC, UKCA,  . The approvals of your battery pack can be found on the name plate and in chapter 9.2 Approvals [▶ 22].
9	Reference to safety and warning instructions, power supply and battery leakage protection
10	Pin assignment of the 5-pin terminal strip

4 Commissioning

In order to use the battery pack, you must first transport and unpack it. You can then install the battery pack in the control cabinet and connect it to the PC.

4.1 Transport and unpacking

Note the specified transport and storage conditions (see Chapter 7 [Technical data \[► 20\]](#)).

The battery pack contains two leak-proof VRLA batteries. The batteries are permanently installed in a corrosion-resistant stainless steel housing and short-circuit proof with electrical fuse protection.

Despite the robust design of the unit, the components are sensitive to strong vibrations and impacts. Transporting a control cabinet with a built-in battery pack can result in excessive impact on the DIN rail and the battery pack. Therefore, the transport of the battery pack in the control cabinet is not possible. During transport the battery pack must therefore be protected from excessive mechanical stress. Appropriate packaging of the battery pack, in particular the original packaging, can improve the vibration resistance during transport.

On our original packaging you will find the following sticker:

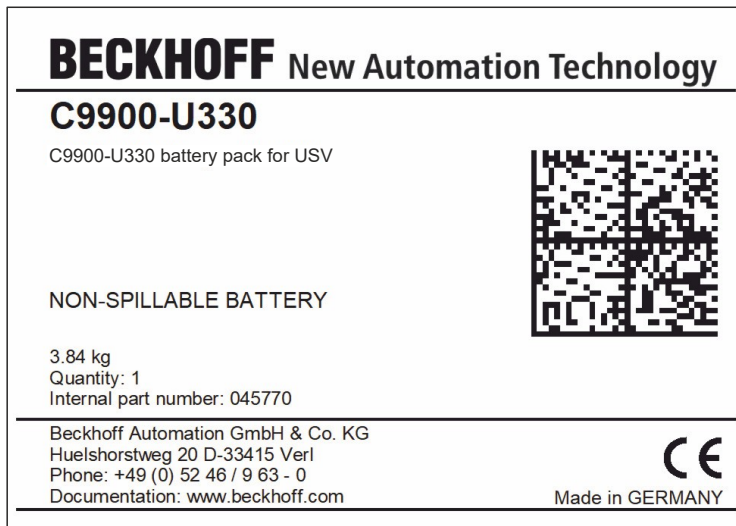

Fig. 3: C9900-U330_shipping label

Use the original packaging for re-transportation to ensure the required labeling of the battery packs by the sticker.

The battery pack is not regulated for air transport as it meets the requirements of Special Provision - "A67" according to the International Air Transportation Association (IATA) and the International Civil Aviation Organization (ICAO).

In addition, the battery pack meets vibration and differential pressure tests in accordance with International Maritime Dangerous Goods (IMDG) regulations.

Unpacking

Proceed as follows to unpack the battery pack:

1. Check the packaging for transport damage.
2. Remove packaging.
3. Keep the packaging for possible future transport.
4. Check your delivery for completeness by comparing it with your order.
5. Check the contents for visible shipping damage.

6. In case of discrepancies between the package contents and the order, or in case of transport damage, please inform Beckhoff Service (see Chapter 8.1 [Service and support](#) [[▶ 21](#)]).

4.2 Dimensions

All dimensions are in mm.

Figure 4 shows the dimensions of the battery pack for correct mounting on the DIN rail.

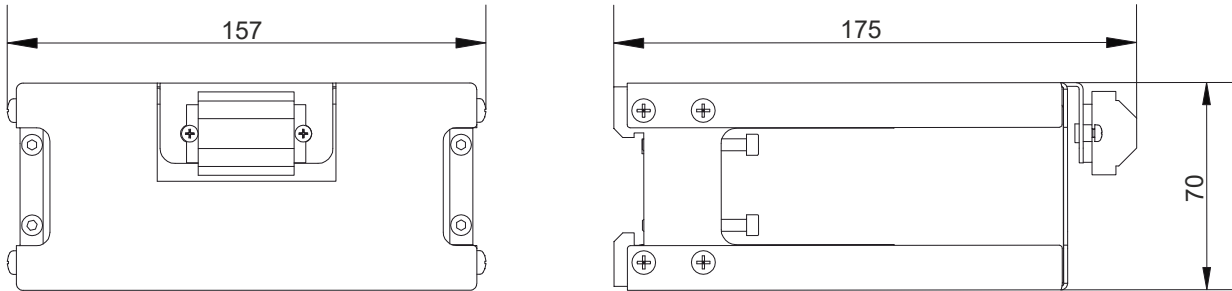

Fig. 4: C9900-U330_dimensions

4.3 Control cabinet installation

⚠ WARNING

Risk of deflagration

A missing or insufficient ventilation of the control cabinet in which the battery pack is mounted can lead to deflagration in the control cabinet.

- Ensure sufficient ventilation of the control cabinet according to EN 50272-2 (see below).

NOTE

Extreme environmental conditions

Extreme environmental conditions can cause damage to the battery pack.

- Avoid extreme environmental conditions.
- Protect the battery pack from moisture and heat.

Ventilation control cabinet

In the event of a fault or heavy load, hydrogen may leak from the batteries inside the battery pack. Oxygen is present in the control cabinet. If the hydrogen cannot escape from the control cabinet and the hydrogen concentration in the control cabinet exceeds a value of 4 %_{vol}, an explosive mixture is formed and deflagration may occur in the control cabinet. To keep the hydrogen concentration in the air low and thus reduce the risk of deflagration, you must ensure appropriate ventilation of the control cabinet in accordance with EN 50272-2. You can achieve this through natural ventilation. Equip the control cabinet with openings for air circulation. Position the openings either on opposite walls or in the same wall at least 2 m apart.

Control cabinet installation

The battery pack C9900-U330 is designed for installation in control cabinets of machine and plant technology. The environmental conditions specified for operation must be observed (see chapter 7 [Technical data](#) [► 20]).

If you need the dimensions of the battery pack for mounting, you can get them in chapter 4.2 [Dimensions](#) [► 11].

The C9900-U330 battery pack is mounted on the DIN rail via the back of the battery pack. Two types of DIN rail are commonly used in system engineering:

- TS 35 x 7.5
- TS 35 x 15

A flat DIN rail of type TS 35 x 7.5 is too weak for the battery pack. Accordingly, you may only mount the battery pack on a DIN rail of type TS 35 x 15.

To mount the battery pack on the DIN rail, follow the steps below, shown in Figure 5:

1. Place the battery pack on the DIN rail via the rear side (section A).
2. Tighten the four socket head screws (section B).

⇒ You have installed the battery pack on the DIN rail.

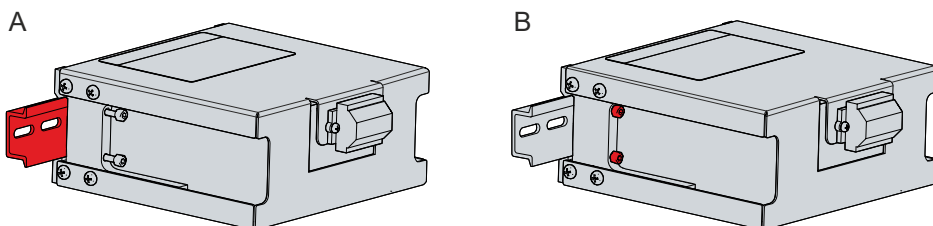

Fig. 5: C9900-U330_DIN rail installation

4.4 Connect battery pack

⚠ CAUTION

Risk of electric shock

Dangerous touch voltages can lead to electric shock. To avoid electric shock, observe the following:

- Never plug or unplug the battery pack cable during a thunderstorm.
- Provide protective earthing for handling the battery pack.

NOTE

Incorrect connection procedure

Incorrect procedure when connecting the cable can cause hardware damage.

- Follow the documented procedure for connecting the cable.
- Always connect the cable first and only then switch on the power supply of the connected PC.

After you have mounted the battery pack in the control cabinet, you can connect it to the PC.

Grounding

Potential differences are minimized and electrical currents are diverted to the ground through protective earthing or potential equalization of electronic devices. This is to prevent dangerous touch voltages and electromagnetic interference.

Connecting the battery pack

You must connect the battery pack to the PC. For this purpose, there is a 5-pin 2-wire terminal strip with mounting flange on the battery pack housing (see Fig. 6).

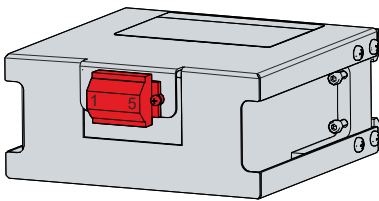

Fig. 6: C9900-U330_position terminal strip

Table 3: Pin assignment terminal strip

Pin	Function	
1	-	24 V battery pack
2	+	
3	⊕	
4	0 V	Power supply
5	24 V	

You can connect two wires on each side of a terminal of the terminal strip. For this purpose, you must use double wire end sleeves (see Fig. 7).

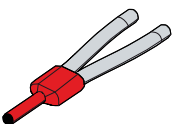

Fig. 7: C9900-U330_double wire end sleeve

PIN 4 and 5 of the battery pack are available for looping through a 24 V power supply to the PC. Accordingly, you can connect a three-core sheathed cable with plus and minus of the supply voltage as well as protective earth to the battery pack and then connect the battery pack to the PC with a five-core sheathed cable.

If the supply voltage fails, the PC draws the voltage from the charged battery pack, which saves the data and allows the PC to shut down properly.

The intended wiring of the battery pack can be found in the following wiring diagrams suitable for your device.

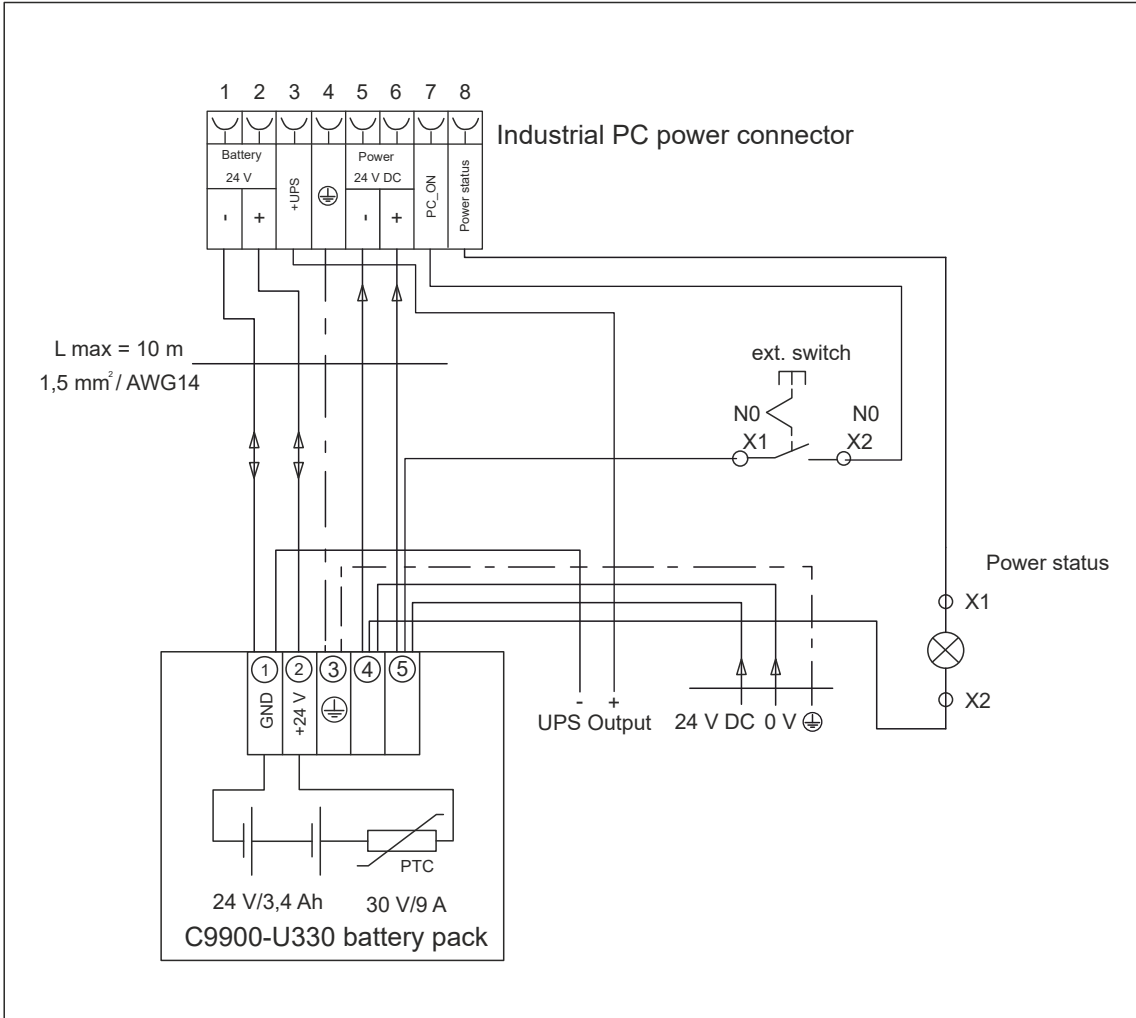

Fig. 8: C9900-U330_wiring diagram-8-pin

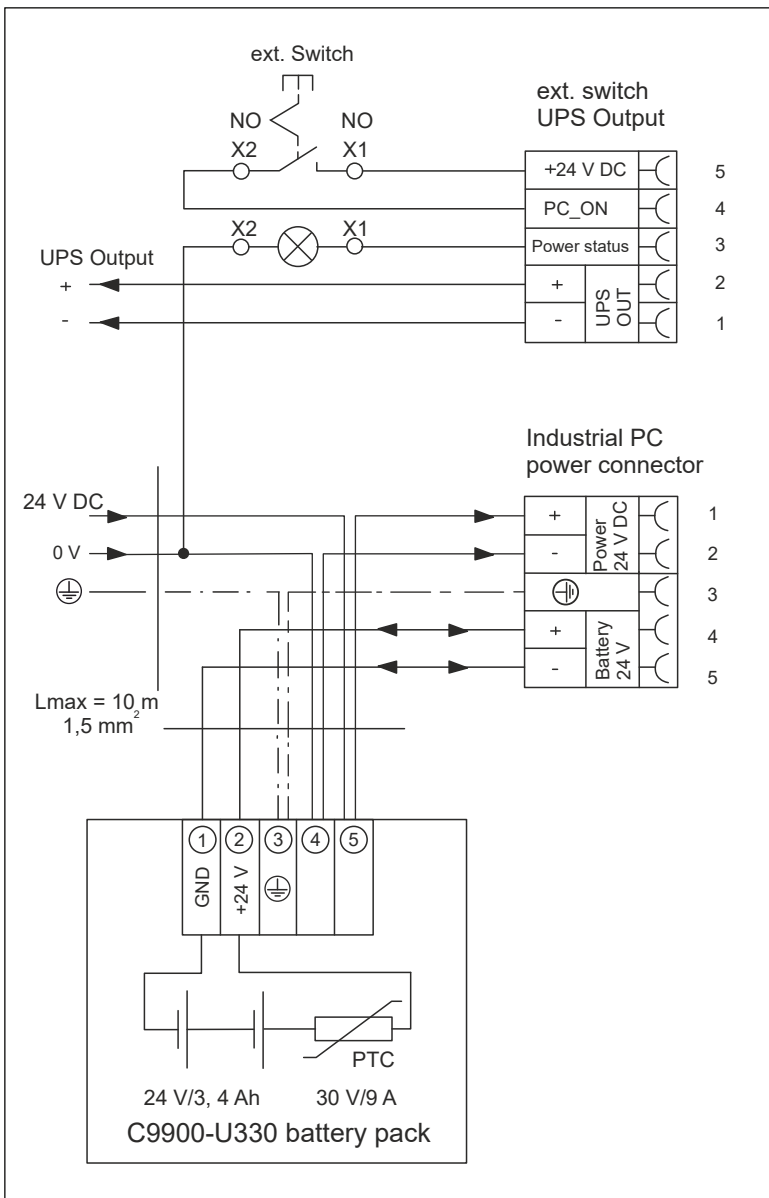

Fig. 9: C9900-U330_wiring diagram-2x5-pin

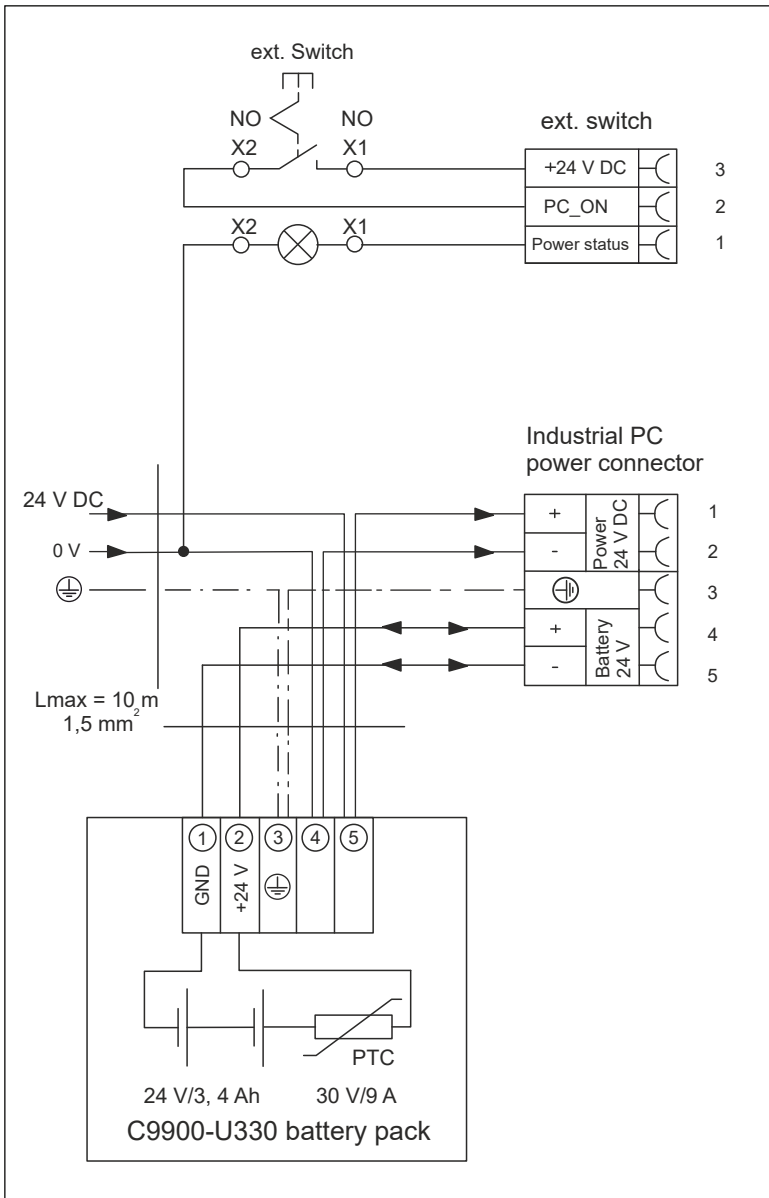

Fig. 10: C9900-U330_wiring diagram-5-and-3-pin

5 Decommissioning

⚠ WARNING

Risk of injury and hardware damage in the event of a short circuit

The batteries can be charged with large amounts of energy. In the event of a short circuit, these can lead to very high currents, which can damage tools and injure users.

- Avoid injuries due to flying sparks and fires as well as damage to the tool by handling the battery pack safely.

NOTE

Hardware damage due to power supply

A connected power supply can cause damage to the battery pack during disassembly.

- Disconnect the cable to the PC and thus the power supply before starting disassembly.

When decommissioning the battery pack, you must first remove all cables connected to the battery pack. You can then remove the battery pack from the control cabinet.

If you do not want to continue using the battery pack, you will receive information on the correct disposal of the battery pack in the further course of the chapter.

Disassembly from the DIN rail

To remove the battery pack from the DIN rail, follow the steps below, shown in Figure 11:

1. Loosen the four hexagon socket screws on the mounting notches (section A).
2. Remove the battery pack from the DIN rail (section B).

⇒ You have removed the battery pack from the DIN rail.

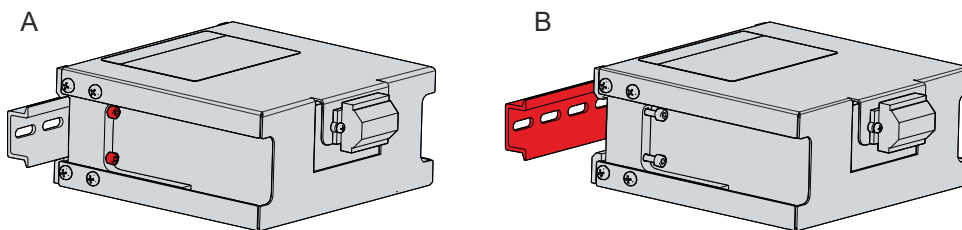

Fig. 11: C9900-U330_disassembly from the DIN rail

Disposal of the battery pack

When disposing of the battery pack, be sure to observe the national electronic waste regulations.

For disposal, you must remove and dismantle the battery pack.

To dismantle the battery pack, follow the steps shown in the figure 12:

1. Remove the four M4 x 20 screws and the four M4 x 8 screws (section A).
2. Pull the angle plate from the housing (section B).
3. Remove the mounting elements (section C).
4. Pull off the fire protection plate (section D).

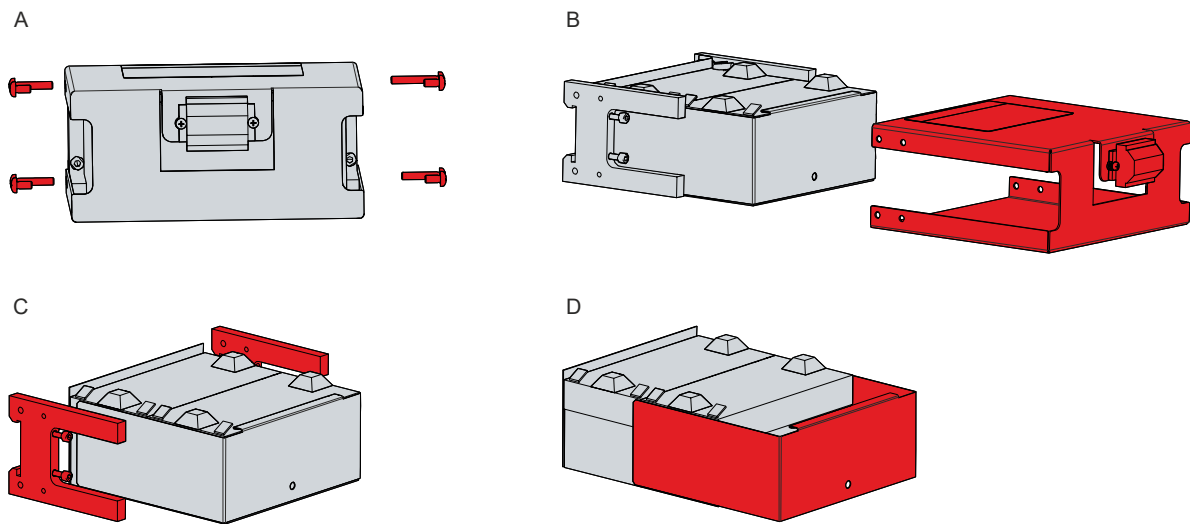

Fig. 12: C9900-U330_dismantling battery pack

After you have dismantled the battery pack, you should insulate the terminals of the removed batteries. For this purpose, you can use, for example, insulating tape. You can then dispose of the components as follows:

- Dispose of batteries properly.
- Send plastic parts (polycarbonate, polyamide (PA6.6)) for plastics recycling.
- Take the angle plate to the metal recycling collection point.

6 Maintenance

Maintenance measures increase the efficiency of the device by ensuring long-term functionality. Cleaning the device contributes to this.

Beckhoff generally recommends replacing the battery pack 5 years after production. You can find the coded production date of your battery pack on the name plate. The coding is as follows:

- Example: V0916 = 16.09.2021
- V = the coded production year 2021
- 09 = Production month September
- 16 = Manufacturing day

The years of manufacture are coded in letters as follows:

- Letters H to V = production years 2007-2021

Cleaning

NOTE

Unsuitable cleaning agents

The use of unsuitable cleaning agents can damage the device.

- Clean the battery pack only as specified.

It is essential to observe the following points when cleaning the battery pack:

- Make sure that no dust gets into the battery pack.
- Only use a vacuum cleaner to clean the battery pack. The device does not have to be switched off for this.
- Never use compressed air to clean the battery pack.

Avoid the following cleaning agents:

- Detergents with scouring or abrasive components
- Metal cleaning objects such as razor blades or steel spatulas

Repair

Only the manufacturer may repair the device. If a repair should be necessary, contact Beckhoff Service (see Chapter 9.1 [Service and support](#) [▶ 21]).

7 Technical data

Product designation	C9900-U330
Dimensions (W x H x D)	157 x 70 x 175 mm
Weight	3.3 kg
Electrical data	Nominal voltage: 24 V Capacity: 3.4 Ah (discharge over 20 hours) Internal resistance: 120 mOhm Fuse protection: 9 A/30 V via PTC element Final charge voltage: between 27.2 V and 27.4 V
Vibration resistance (sinusoidal vibration)	EN 60068-2-6: 10 to 58 Hz: 0.035 mm 58 to 500 Hz: 0.5 G (~ 5 m/s ²)
Shock resistance (shock)	EN 60068-2-27: 5 G (~ 50 m/s ²), duration: 30 ms
EMC interference immunity	conforms to EN 61000-6-2
Permitted ambient temperature	0 °C to +50 °C (transport / storage) -20 °C to +50 °C (transport)
Permissible relative air humidity	Maximum 95 %, no condensation
Transport and storage	The same values for air humidity and shock resistance are to be observed during transport and storage as in operation. The shock resistance during transport can be improved by appropriate packaging of the battery pack.

8 Appendix

8.1 Service and support

Beckhoff and its worldwide subsidiaries offer comprehensive service and support, providing fast and competent assistance with all issues relating to Beckhoff products and system solutions.

Beckhoff Service

The Beckhoff Service Center supports you in all matters of after-sales service:

- on-site service
- repair service
- spare parts service
- hotline service

Hotline: + 49 (0) 5246/963-460

Fax: + 49 (0) 5246/963-479

email: service@beckhoff.com

In case of service, please state the coded production date of your battery pack, which you can find on the name plate.

Beckhoff Support

Support offers you comprehensive technical assistance, helping you not only with the application of individual Beckhoff products, but also with other, wide-ranging services:

- World-wide support
- design, programming and commissioning of complex automation systems
- extensive training program for Beckhoff system components

Hotline: + 49 (0) 5246/963-157

Fax: + 49 (0) 5246/963-9157

email: support@beckhoff.com

Headquarters

Beckhoff Automation GmbH & Co. KG
Hülshorstweg 20
33415 Verl
Germany

Telephone: + 49 (0) 5246/963-0

Fax: + 49 (0) 5246/963-198

email: info@beckhoff.de

The addresses of the worldwide Beckhoff subsidiaries and agencies can be found on our website at <http://www.beckhoff.com/>.

You will also find further documentation for Beckhoff components there.

8.2 Approvals

The device has the following approvals:

- CE
- EAC
- UKCA

You will find all other applicable approvals on the name plate of your device.

List of figures

Fig. 1	C9900-U330_Structure.....	8
Fig. 2	C9900-U330_name plate.....	9
Fig. 3	C9900-U330_shipping label	10
Fig. 4	C9900-U330_dimensions	11
Fig. 5	C9900-U330_DIN rail installation	12
Fig. 6	C9900-U330_position terminal strip	13
Fig. 7	C9900-U330_double wire end sleeve.....	13
Fig. 8	C9900-U330_wiring diagram-8-pin.....	14
Fig. 9	C9900-U330_wiring diagram-2x5-pin	15
Fig. 10	C9900-U330_wiring diagram-5-and-3-pin	16
Fig. 11	C9900-U330_disassembly from the DIN rail	17
Fig. 12	C9900-U330_dismantling battery pack.....	18

List of tables

Table 1	Key for C9900-U330 structure	8
Table 2	Key for C9900-U330 name plate	9
Table 3	Pin assignment terminal strip.....	13

More Information:
www.beckhoff.com/c9900-u330

Beckhoff Automation GmbH & Co. KG
Hülshorstweg 20
33415 Verl
Germany
Phone: +49 5246 9630
info@beckhoff.com
www.beckhoff.com

