

BECKHOFF

CB3060

Manual

rev. 1.4

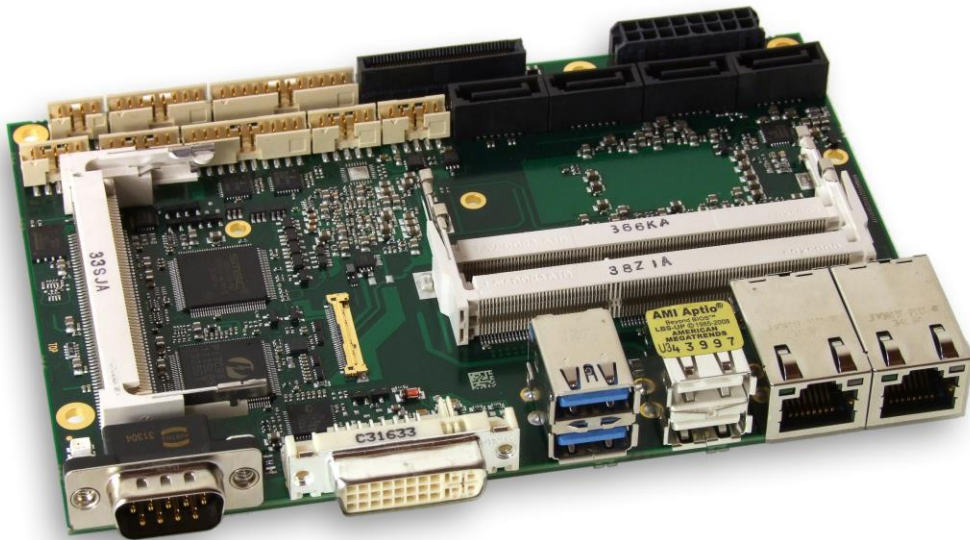

Beckhoff Automation GmbH & Co. KG
Eiserstr. 5
33415 Verl
Germany

phone: +49 (0) 52 46/963-0
fax: +49 (0) 52 46/963-198
email: info@beckhoff.de
web: www.beckhoff.de

Contents

0	Document History.....	6
1	Introduction	7
1.1	Notes on the Documentation	7
1.1.1	Disclaimer	7
1.1.2	Copyright.....	7
1.2	Safety Instructions	8
1.2.1	Disclaimer	8
1.2.2	Description of Safety Symbols	9
1.3	Essential Safety Measures	10
1.3.1	Operator's Obligation to Exercise Diligence	10
1.3.2	National Regulations Depending on the Machine Type	10
1.3.3	Operator Requirements	10
1.4	Functional Range.....	11
2	Overview	12
2.1	Features.....	12
2.2	Specifications and Documents	14
3	Connectors	15
3.1	Connector Map	16
3.2	Power Supply.....	17
3.3	System	18
3.4	Memory	19
3.5	VGA/DVI	22
3.6	DVI/HDMI/DisplayPort	24
3.7	USB 1-4	26
3.8	USB 5-10	27
3.9	LAN	28
3.10	Audio.....	29
3.11	SATA Interfaces.....	30
3.12	Serial Interface COM1	31
3.13	Serial Ports COM2 through COM4	32
3.14	PCI-Express.....	34
3.15	Mini-PCI	36
3.16	GPIO	38
3.17	Fan Connectors	39
4	State LEDs	40
5	BIOS Settings.....	41
5.1	General Remarks.....	41
5.2	Main	42
5.3	Advanced.....	44
5.3.1	PCI Subsystem Settings	46
5.3.2	ACPI Settings.....	48
5.3.3	Trusted Computing	49
5.3.4	CPU Configuration	50
5.3.5	SATA Configuration	53
5.3.6	AMT Configuration.....	56
5.3.7	Power Controller Options.....	58

Contents

5.3.8	USB Configuration	60
5.3.9	Super IO Configuration	61
5.3.10	H/W Monitor	63
5.3.11	Serial Port Console Redirection.....	65
5.3.12	Network Stack.....	68
5.3.13	Intel(R) Ethernet Connection I218-LM.....	69
5.3.14	Intel(R) I210 Gigabit Network Connection	71
5.3.15	Driver Health	73
5.4	Chipset.....	75
5.4.1	PCH-IO Configuration.....	76
5.4.2	System Agent (SA) Configuration.....	83
5.5	Boot.....	93
5.5.1	CSM16 Parameters	95
5.5.2	CSM Parameters	96
5.6	Security	97
5.6.1	Secure Boot Menu	98
5.7	Save & Exit	101
5.8	BIOS-Update	102
6	Mechanical Drawings.....	103
6.1	PCB: Mounting Holes	103
6.2	PCB: Pin 1 Dimensions - Top.....	104
6.3	PCB: Die Center	105
7	Technical Data	106
7.1	Electrical Data.....	106
7.2	Environmental Conditions.....	106
7.3	Thermal Specifications	107
8	Support and Service	108
8.1	Beckhoff's Branch Offices and Representatives	108
8.2	Beckhoff Headquarters	108
8.2.1	Beckhoff Support	108
8.2.2	Beckhoff Service	108
I	Annex: Post-Codes	110
II	Annex: Resources.....	111
	IO Range	111
	Memory Range.....	111
	Interrupt	111
	PCI Devices.....	112
	SMB Devices.....	112

0 Document History

Version	Changes
0.1	first pre-release
1.0	first released version
1.1	updated BIOS setup updated status code RGB LED
1.2	corrected LAN pinout; corrected FAN pinout
1.3	Chapter 3.6: changed I-PEX pinout
1.4	added UL conformity notice for RTC battery corrected PCIe pinout

All company names, brand names, and product names referred to in this manual are registered or unregistered trademarks of their respective holders and are, as such, protected by national and international law.

1 Introduction

1.1 Notes on the Documentation

This description is only intended for the use of trained specialists in control and automation engineering who are familiar with the applicable national standards. It is essential that the following notes and explanations are followed when installing and commissioning these components.

The responsible staff must ensure that the application or use of the products described satisfy all the requirements for safety, including all the relevant laws, regulations, guidelines and standards.

1.1.1 Disclaimer

The documentation has been prepared with care. The products described are, however, constantly under development.

For that reason the documentation is not in every case checked for consistency with performance data, standards or other characteristics.

None of the statements of this manual represents a guarantee (Garantie) in the meaning of § 443 BGB of the German Civil Code or a statement about the contractually expected fitness for a particular purpose in the meaning of § 434 par. 1 sentence 1 BGB.

In the event that it contains technical or editorial errors, we retain the right to make alterations at any time and without warning.

No claims for the modification of products that have already been supplied may be made on the basis of the data, diagrams and descriptions in this documentation.

1.1.2 Copyright

© This documentation is copyrighted. Any reproduction or third party use of this publication, whether in whole or in part, without the written permission of Beckhoff Automation GmbH & Co. KG, is forbidden.

1.2 Safety Instructions

Consider the following safety instructions and descriptions!

Product specific safety instructions are to be found on the following pages or in the areas mounting, wiring, commissioning etc.

1.2.1 Disclaimer

All the components are supplied in particular hardware and software configurations appropriate for the application. Modifications to hardware or software configurations other than those described in the documentation are not permitted, and nullify the liability of Beckhoff Automation GmbH & Co. KG.

1.2.2 Description of Safety Symbols

The following safety symbols are used in this documentation. You have to read the safety symbols carefully and adhere them strictly!

 DANGER	Acute risk of injury! If you do not adhere the safety advise adjoining this symbol, there is immediate danger to life and health of individuals!
--	--

 WARNING	Risk of injury! If you do not adhere the safety advise adjoining this symbol, there is danger to life and health of individuals!
---	--

 CAUTION	Hazard to devices and environment If you do not adhere the safety advise adjoining this symbol, there is obvious hazard to individuals!
--	---

 Attention	Hazard to devices and environment If you do not adhere the notice adjoining this symbol, there is obvious hazard to materials and environment.
---	--

 Notice	Note or pointer This symbol indicates information that contributes to better understanding.
--	---

1.3 Essential Safety Measures

1.3.1 Operator's Obligation to Exercise Diligence

The operator must ensure that

- the product is only used for its intended purpose
- the product is only operated in sound condition and in working order
- the instruction manual is in good condition and complete, and always available for reference at the location where the products are used
- the product is only used by suitably qualified and authorised personnel
- the personnel is instructed regularly about relevant occupational safety and environmental protection aspects
- the operating personnel is familiar with the operating manual and in particular the safety notes contained herein

1.3.2 National Regulations Depending on the Machine Type

Depending on the type of machine and plant in which the product is used, national regulations governing the controllers of such machines will apply, and must be observed by the operator. These regulations cover, amongst other things, the intervals between inspections of the controller. The operator must initiate such inspections in good time.

1.3.3 Operator Requirements

- Read the operating instructions

All users of the product must have read the operating instructions for the system they work with.

- System know-how

All users must be familiar with all accessible functions of the product.

1.4 Functional Range

The descriptions contained in the present documentation represent a detailed and extensive product description. As far as the described motherboard was acquired as an integral component of an Industrial PC from Beckhoff Automation GmbH & Co. KG, this product description shall be applied only in limited scope. Only the contractually agreed specifications of the corresponding Industrial PC from Beckhoff Automation GmbH & Co. KG shall be relevant. Due to several models of Industrial PCs, variations in the component placement of the motherboards are possible. Support and service benefits for the built-in motherboard will be rendered by Beckhoff Automation GmbH & Co. KG exclusively as specified in the product description (inclusive operation system) of the particular Industrial PC.

2 Overview

2.1 Features

The CB3060 is a highly complex 3,5-inch board which incorporates complete motherboard functionality. It's based on Intel®'s QM87 chipset combined with Intel® CPUs of the 4th Generation Core™ families. Modern low voltage DDR3L technology provides top-notch memory performance, accommodating up to 16 GByte of RAM (DDR3L-1600) via SO-DIMM204. It also provides a PCI bus (via mPCI connector), a PCI-Express bus (via a 2x40 pin custom connector) and additional peripheral devices such as four serial interfaces, two Gigabit Ethernet interfaces (LAN), four SATA channels (two of which offering up to 6Gb/s), an audio interface (HDA 5.1), eleven USB channels, and two DVI/HDMI connectors with CRT available through DVI-I, and DisplayPort available on a 30pin I-PEX connector. In addition the board serves via the integrated Trusted Platform Module as Trusted Computing Platform and provides essential safety functions.

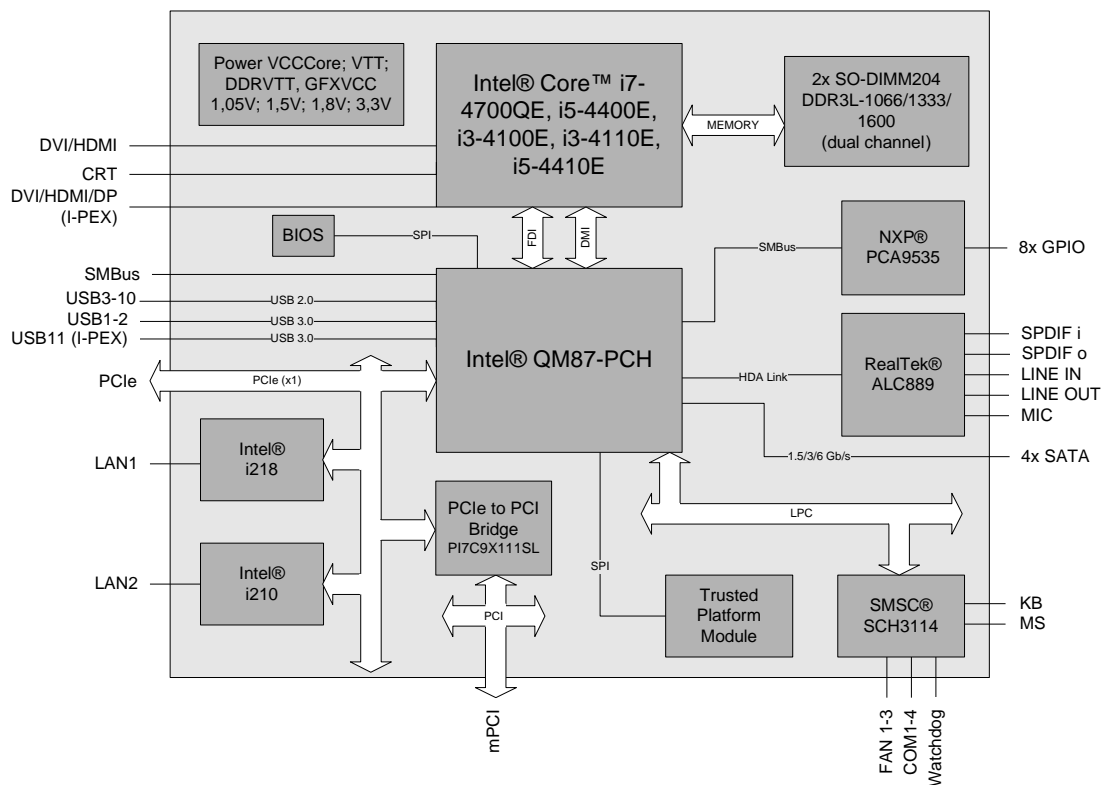

- Suitable CPUs: Intel® Core™ i7-4700QE, i5-4400E, i3-4100E, i3-4110E, i5-4410E
- Chipset Intel® QM87 PCH
- Two SO-DIMM204-sockets for up to 16 GByte DDR3L-1600
- PCI bus via mPCI connector
- PCI-Express bus (four x1 or one x4) via 2x40pin custom connector
- Four serial interfaces COM1 to COM4
- Two LAN interfaces Ethernet 10/100/1000 (Base-T)
- Four SATA channels (2x 1.5/3/6Gb/s, 2x 1.5/3 Gb/s transfer rate)
- PS2 keyboard / mouse interface
- 11 USB 2.0 interfaces (4x external, 6x internal, 1x on I-PEX connector)
- BIOS AMI® Aptio
- CRT connection
- Two DVI/HDMI connectors (1x DVI-I, 1x I-PEX MiniCoax DVI/HDMI/DP)

- HDA compatible sound controller with SPDIF in and out
- 8x GPIO
- TPM Modul
- Watchdog
- RTC with external CMOS battery
- Three regulated fan connectors
- 5V supply
- Format: 102 mm x 147 mm

2.2 Specifications and Documents

In making this manual and for further reading of technical documentation, the following documents, specifications and web-pages were used and are recommended.

- PCI specification
Version 2.3 resp. 3.0
www.pcisig.com
- Mini-PCI specification
Version 1.0
www.pcisig.com
- PCI Express® Base specification
Version 2.0
www.pcisig.com
- ACPI specification
Version 5.0
www.acpi.info
- USB specifications
www.usb.org
- SM-Bus specification
Version 2.0
www.smbus.org
- Intel® Chip Description
4th Gen. Intel® Core™ Processor Family Mobile datasheet
www.intel.com
- Intel® Chipset Description
Intel® 8 Series Chipset datasheet
www.intel.com
- Intel® Chip Description
i210 Datasheet
www.intel.com
- Intel® Chip Description
i218 Datasheet
www.intel.com
- Realtek® Chip Description
ALC885/889 Datasheet
www.realtek.com.tw
- SMSC® Chip Description
SCH3114 Datasheet
www.smsc.com
(NDA required)
- American Megatrends®
Aptio™ Text Setup Environment (TSE) User Manual
www.ami.com
- American Megatrends®
Aptio™ 4.x Status Codes
www.ami.com

3 Connectors

This section describes all the connectors found on the CB3060.



Notice

Please consider the requirements on the cabling!

For most interfaces, the cables must meet certain requirements. For instance, USB 2.0 requires twisted and shielded cables to reliably maintain full speed data rates. Restrictions on maximum cable length are also in place for many high speed interfaces and for power supply. Please refer to the respective specifications and use suitable cables at all times.

3.1 Connector Map

Please use the connector map below for quick reference. Only connectors on the component side are shown. For more information on each connector refer to the table below.

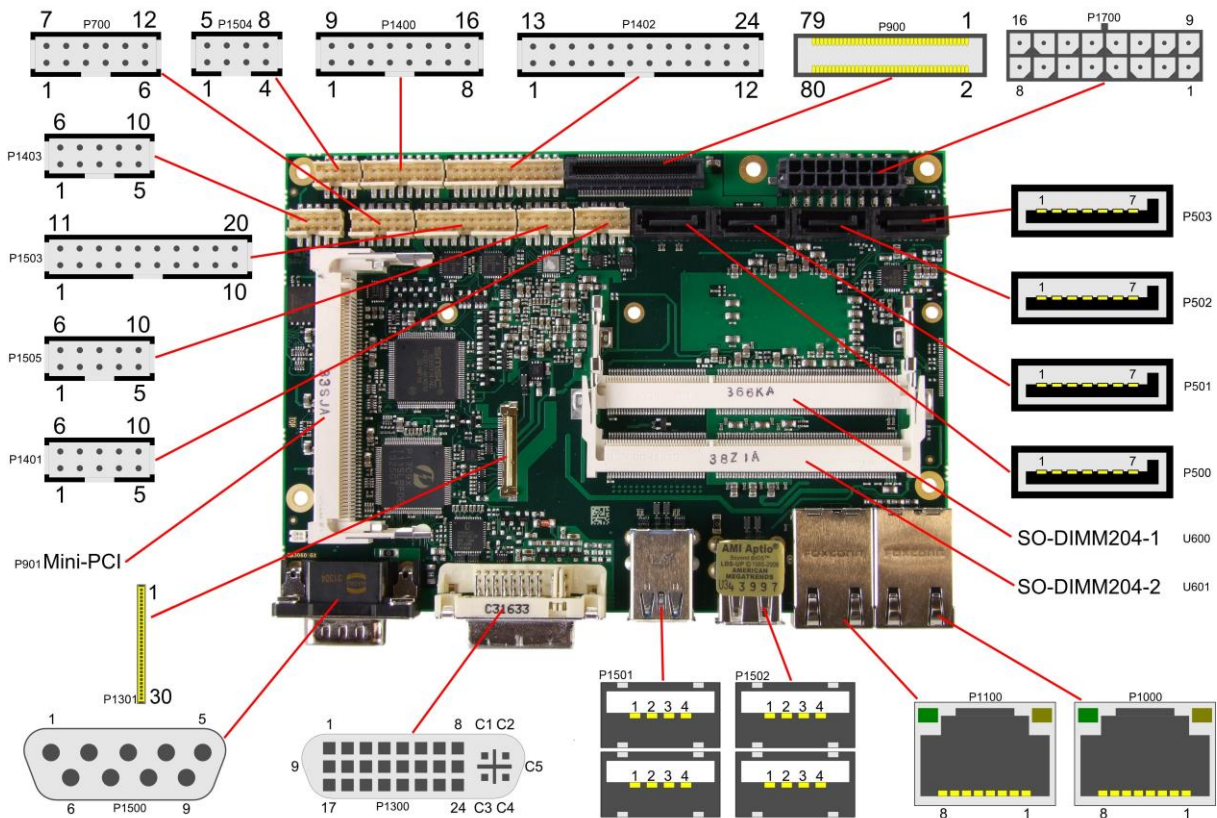

Ref-No.	Function	Page
P500/1/2/3	"SATA Interfaces"	p. 30
U600/1	"Memory"	p. 19
P700	"GPIO"	p. 38
P900	"PCI-Express"	p. 34
P901	"Mini-PCI"	p. 36
P1000/1100	"LAN"	p. 28
P1300	"VGA/DVI"	p. 22
P1301	"DVI/HDMI/DisplayPort"	p. 24
P1400/1504	"USB 5-10"	p. 27
P1401	"Fan Connectors"	p. 39
P1402	"System"	p. 18
P1403	"Audio"	p. 29
P1500	"Serial Interface COM1"	p. 31
P1503/5	"Serial Ports COM2 through COM4"	p. 32
P1501/2	"USB 1-4"	p. 26
P1700	"Power Supply"	p. 17

3.2 Power Supply

The power supply of the hardware module is realized via a 2x8-pin connector (Molex PS 43045-1619, mating connector: Molex PS 43025-16xx). The 12 volt supply is needed for PCI-Express cards and for the fan connector. COM3 RXD and TXD can also be used for connecting a second power supply unit, e. g. for UPS. As an ordering option SMBus signals SCL/SDA can be provided (replacing COM3 TXD/RXD).

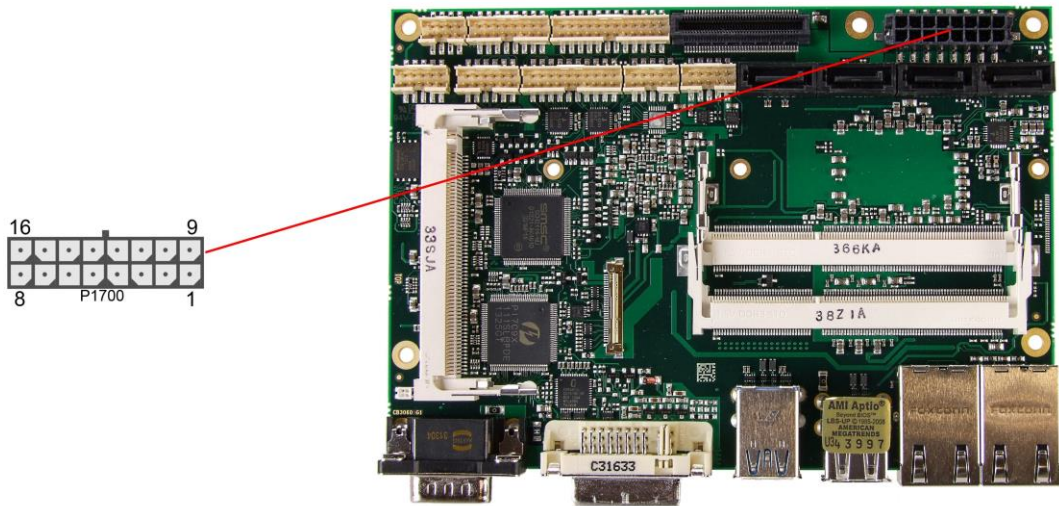

Description	Name	Pin		Name	Description
COM3 transmit data	TXD	1	9	RXD	COM3 receive data
PSU on	PS-ON	2	10	PWRGD	Powergood
powerbutton PSU	PWRBTN#	3	11	SVCC	standby-supply 5V
12 volt supply	12V	4	12	12V	12 volt supply
ground	GND	5	13	GND	ground
ground	GND	6	14	GND	ground
5 volt supply	VCC	7	15	VCC	5 volt supply
5 volt supply	VCC	8	16	VCC	5 volt supply

3.3 System

A number of signals for system control and for SMBus communication are provided through a 2x12 pin connector (FCI 98424-G52-24LF, mating connector FCI 90311-024LF). This connector combines signals for power button, reset, keyboard, speaker, and several LEDs such as harddisk LED, and suspend LED, and three additional LEDs which are driven by GPIOs. Of these three GPIO-LEDs, LED1 and LED2 are already provided with a series resistor. SMBus capable devices can also be connected.

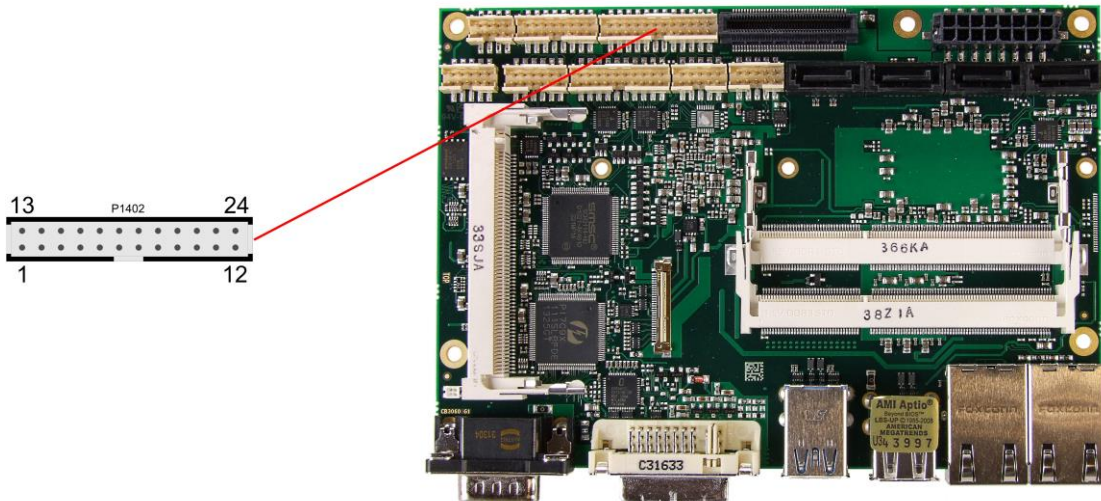

Pinout 2x12pin connector:

Description	Name	Pin	Name	Description
ground	GND	1	13	3.3V 3.3V supply
reset to ground	RSTBTN#	2	14	PWRBTN# on/suspend button
LED suspend / ACPI	S-LED	3	15	S3.3V standby supply 3.3V
LED harddisk	SATALED	4	16	GPIOLED3 LED GPIO device 3
LED GPIO device 1	GPIOLED1	5	17	BATT battery
LED GPIO device 2	GPIOLED2	6	18	SMBALERT# SMB alert
SMB Clock	SMBCLKEX	7	19	SMBDATEX SMB data
speaker to 5V	SPEAKER	8	20	SVCC standby supply 5V
keyboard clock	KCLK	9	21	KDAT keyboard data
ground	GND	10	22	VCC 5V supply
ground	GND	11	23	VCC 5V supply
ground	GND	12	24	VCC 5V supply



Notice

UL Conformity

The board already implements all required technical measures for UL conformity. Connect the battery directly. There are no further technical measures required!

3.4 Memory

Conventional SO-DIMM204 memory modules, as familiar from notebook computers, are used to equip the board with memory. For technical and mechanical reasons it is possible that particular memory modules cannot be employed. Please ask your distributor for recommended memory modules.

With currently available SO-DIMM204 modules a memory extension up to 16 GByte is possible (DDR3L-1600).

All timing parameters for different memory modules are automatically set by BIOS.

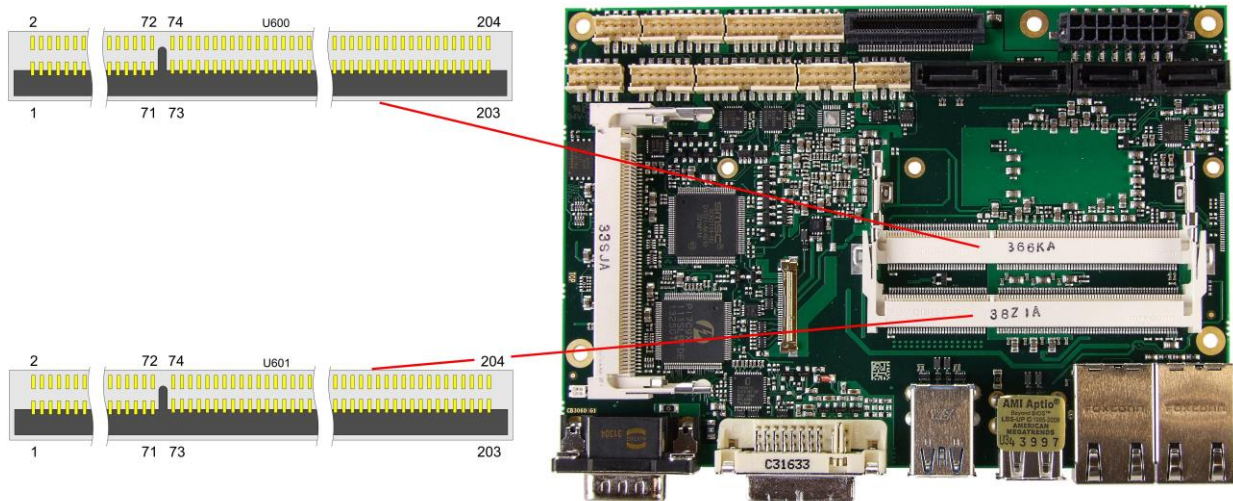

Pinout SO-DIMM204:

Description	Name	Pin	Name	Description
memory reference current	REF-DQ	1	2	GND
ground	GND	3	4	DQ4
data 0	DQ0	5	6	DQ5
data 1	DQ1	7	8	GND
ground	GND	9	10	DQS0#
data mask 0	DM0	11	12	DQS0
ground	GND	13	14	GND
data 2	DQ2	15	16	DQ6
data 3	DQ3	17	18	DQ7
ground	GND	19	20	GND
data 8	DQ8	21	22	DQ12
data 9	DQ9	23	24	DQ13
ground	GND	25	26	GND
data strobe 1 -	DQS1#	27	28	DM1
data strobe 1 +	DQS1	29	30	RESET#
ground	GND	31	32	GND
data 10	DQ10	33	34	DQ14
data 11	DQ11	35	36	DQ15
ground	GND	37	38	GND
data 16	DQ16	39	40	DQ20
data 17	DQ17	41	42	DQ21
ground	GND	43	44	GND
data strobe 2 -	DQS2#	45	46	DM2
data strobe 2 +	DQS2	47	48	GND
ground	GND	49	50	DQ22
data 18	DQ18	51	52	DQ23

Description	Name	Pin		Name	Description
data 19	DQ19	53	54	GND	ground
ground	GND	55	56	DQ28	data 28
data 24	DQ24	57	58	DQ29	data 29
data 25	DQ25	59	60	GND	ground
ground	GND	61	62	DQS3#	data strobe 3 -
data mask 3	DQM3	63	64	DQS3	data strobe 3 +
ground	GND	65	66	GND	ground
data 26	DQ26	67	68	DQ30	data 30
data 27	DQ27	69	70	DQ31	data 31
ground	GND	71	72	GND	ground
clock enables 0	CKE0	73	74	CKE1	clock enables 1
1.5 volt supply	1.5V	75	76	1.5V	1.5 volt supply
reserved	N/C	77	78	(A15)	reserved
SDRAM bank 2	BA2	79	80	A14	address 14
1.5 volt supply	1.5V	81	82	1.5V	1.5 volt supply
address 12 (burst chop)	A12/BC#	83	84	A11	address 11
address 9	A9	85	86	A7	address 7
1.5 volt supply	1.5V	87	88	1.5V	1.5 volt supply
address 8	A8	89	90	A6	address 6
address 5	A5	91	92	A4	address 4
1.5 volt supply	1.5V	93	94	1.5V	1.5 volt supply
address 3	A3	95	96	A2	address 2
address 1	A1	97	98	A0	address 0
1.5 volt supply	1.5V	99	100	1.5V	1.5 volt supply
Clock 0 +	CK0	101	102	CK1	clock 1 +
Clock 0 -	CK0#	103	104	CK1#	clock 1 -
1.5 volt supply	1.5V	105	106	1.5V	1.5 volt supply
address 10 (auto precharge)	A10/AP	107	108	BA1	SDRAM bank 1
SDRAM Bank 0	BA0	109	110	RAS#	row address strobe
1.5 volt supply	1.5V	111	112	1.5V	1.5 volt supply
write enable	WE#	113	114	S0#	chip select 0
column address strobe	CAS#	115	116	ODT0	on die termination 0
1.5 volt supply	1.5V	117	118	1.5V	1.5 volt supply
address 13	A13	119	120	ODT1	on die termination 1
Chip Select 1	S1#	121	122	N/C	reserved
1.5 volt supply	1.5V	123	124	1.5V	1.5 volt supply
reserved	(TEST)	125	126	REF-CA	reference current
ground	GND	127	128	GND	ground
data 32	DQ32	129	130	DQ36	data 36
data 33	DQ33	131	132	DQ37	data 37
ground	GND	133	134	GND	ground
data strobe 4 -	DQS4#	135	136	DQM4	data mask 4
data strobe 4 +	DQS4	137	138	GND	ground
ground	GND	139	140	DQ38	data 38
data 34	DQ34	141	142	DQ39	data 39
data 35	DQ35	143	144	GND	ground
ground	GND	145	146	DQ44	data 44
data 40	DQ40	147	148	DQ45	data 45
data 41	DQ41	149	150	GND	ground
ground	GND	151	152	DQS5#	data strobe 5 -
data mask 5	DQM5	153	154	DQS5	data strobe 5 +
ground	GND	155	156	GND	ground
data 42	DQ42	157	158	DQ46	data 46
data 43	DQ43	159	160	DQ47	data 47
ground	GND	161	162	GND	ground

Description	Name	Pin		Name	Description
data 48	DQ48	163	164	DQ52	data 52
data 49	DQ49	165	166	DQ53	data 53
ground	GND	167	168	GND	ground
data strobe 6 -	DQS6#	169	170	DQM6	data mask 6
data strobe 6	DQS6	171	172	GND	ground
ground	GND	173	174	DQ54	data 54
data 50	DQ50	175	176	DQ55	data 55
data 51	DQ51	177	178	GND	ground
ground	GND	179	180	DQ60	data 60
data 56	DQ56	181	182	DQ61	data 61
data 57	DQ57	183	184	GND	ground
ground	GND	185	186	DQS7#	data strobe 7 -
data mask 7	DQM7	187	188	DQS7	data strobe 7 +
ground	GND	189	190	GND	ground
data 58	DQ58	191	192	DQ62	data 62
data 59	DQ59	193	194	DQ63	data 63
ground	GND	195	196	GND	ground
SPD address 0	SA0	197	198	EVENT#	Event
3.3 volt supply	3.3V	199	200	SDA	SMBus data
SPD address 1	SA1	201	202	SCL	SMBus clock
termination current	VTT	203	204	VTT	termination current

3.5 VGA/DVI

The module is equipped with a standard DVI-I-connector, which can be used to connect a DVI capable device, a standard VGA monitor or an HDMI capable device. External cable adapters that convert from DVI to VGA or HDMI are required to connect standard VGA or HDMI devices.

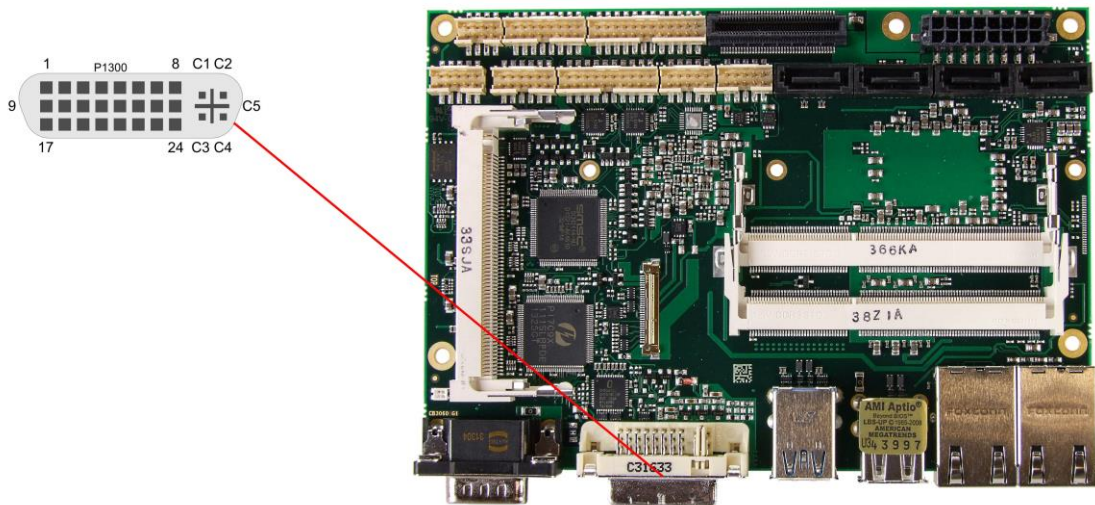

Pinout DVI-I:

Pin	Name	Description
1	TMDSDAT2#	DVI data 2 -
2	TMDSDAT2	DVI data 2 +
3	GND	ground
4	N/C	reserved
5	N/C	reserved
6	DDC CLK	DDC clock (DVI/VGA)
7	DDC DAT	DDC data (DVI/VGA)
8	VSYNC	VGA vertical sync
9	TMDSDAT1#	DVI data 1 -
10	TMDSDAT1	DVI data 1 +
11	GND	ground
12	N/C	reserved
13	N/C	reserved
14	VCC	5 volt supply
15	GND	ground
16	HP_DETECT	hot plug detect
17	TMDSDAT0#	DVI data 0 -
18	TMDSDAT0	DVI data 0 +
19	GND	ground
20	N/C	reserved
21	N/C	reserved
22	GND	ground
23	TMDS CLK	DVI clock
24	TMDS CLK#	DVI clock
C1	RED	VGA red
C2	GREEN	VGA green
C3	BLUE	VGA blue
C4	HSYNC	VGA horizontal sync
C5	GND	ground

3.6 DVI/HDMI/DisplayPort

The CB3060 provides a second DVI interface which is realized as a 30pin flat cable header (I-PEX Cabline-VS 20455-030E-12). Analog VGA is not available on this connector. However, an HDMI device or DisplayPort device can be connected. This custom connector also carries an additional USB interface. Please note that a custom cable design is required.

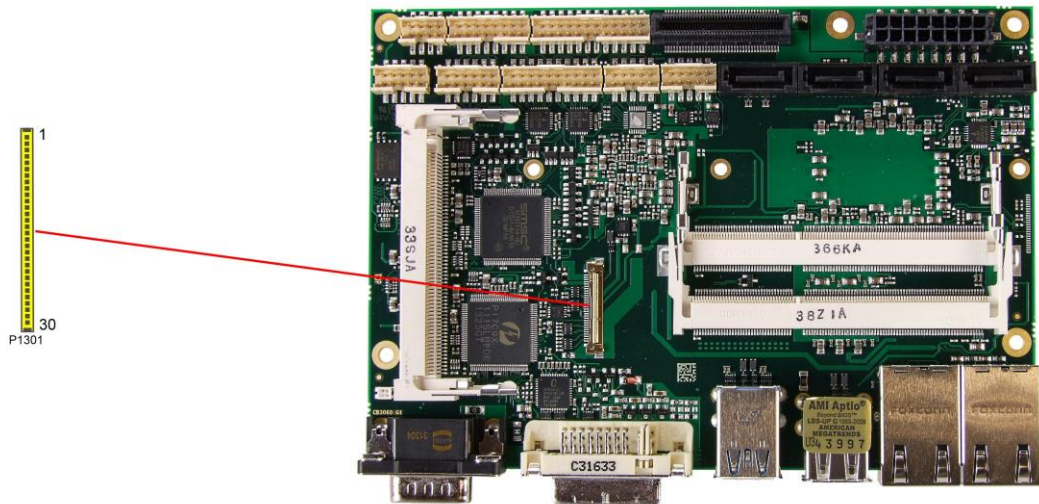

Pinout 30pin connector DVI/HDMI/DisplayPort:

Pin	Name	Description
1	TMDS0#/DP2#	DVI Data 0 - / DP Lane 2 -
2	TMDS0/DP2	DVI Data 0 + / DP Lane 2 +
3	TMDS1#/DP1#	DVI Data 1 - / DP Lane 1 -
4	TMDS1/DP1	DVI Data 1 + / DP Lane 1 +
5	TMDS2#/DP0#	DVI Data 2 - / DP Lane 0 -
6	TMDS2/DP0	DVI Data 2 + / DP Lane 0 +
7	TMDSCLK#/DP3#	DVI Clock - / DP Lane 3 -
8	TMDSCLK/DP3	DVI Clock + / DP Lane 3 +
9	N/C	reserved
10	SEL_DVI/DP#	DVI-DisplayPort Select
11	DDCK/DPAUX	EDID Clock / DP Aux +
12	DDDA/DPAUX#	EDID Data / DP Aux -
13	VCC	5V supply
14	GND	ground
15	HPD	hot plug detect
16	USBVCC	5V supply for USB
17	USBVCC	5V supply for USB
18	N/C	reserved
19	N/C	reserved
20	SSRX#	Super Speed receiver -
21	SSRX	Super Speed receiver +
22	T_D/USB#	USB -
23	T_D/USB	USB +
24	R_D/SSTX#	Super Speed transmitter -
25	R_D/SSTX	Super Speed transmitter
26	3.3V	3.3V supply
27	3.3V	3.3V supply
28	VCC	5V supply

Pin	Name	Description
29	VCC	5V supply
30	VCC	5V supply

3.7 USB 1-4

The USB channels 1 to 4 are available as standard USB connectors.

The USB channels 1 and 2 support USB 3.0, the USB channels 3 and 4 support USB 2.0.

You may note that the setting of USB keyboard or USB mouse support in the BIOS-setup is only necessary and advisable, if the OS offers no USB-support. BIOS-setup can be changed with a USB keyboard without enabling USB keyboard support. Running Windows with these features enabled may lead to significant performance or functionality limitations.

Each USB 2.0 interface provides up to 500 mA current. The USB 3.0 interfaces provide up to 900mA current. All interfaces are protected by an electronically resettable fuse.

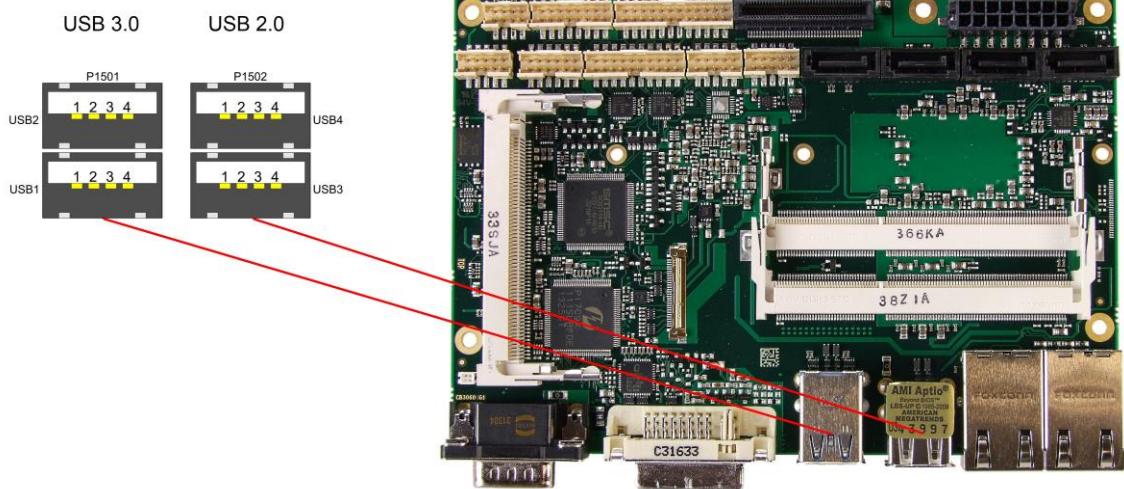

Pinout USB connector for channel X:

Pin	Name	Description
1	VCC	5 volt for USBX
2	USBX#	minus channel USBX
3	USBX	plus channel USBX
4	GND	ground

Pinout USB3.0 connector for channel X:

Pin	Name	Description
1	VCC	5 volt for USBX
2	USBX#	Minus channel USBX
3	USBX	Plus channel USBX
4	GND	ground
5	StdA_SSRX-	SuperSpeed Receiver -
6	StdA_SSRX+	SuperSpeed Receiver +
7	GND	ground
8	StdA_SSTX-	SuperSpeed Transmitter -
9	StdA_SSTX+	SuperSpeed Transmitter +

3.8 USB 5-10

The USB channels 5 to 10 are provided via two connectors, one of which is 2x4pin (FCI 98424-G52-08LF, mating connector FCI 90311-08LF), the other 2x8pin (FCI 98424-G52-16LF, mating connector FCI 90311-016LF).

The USB channels support USB 2.0. You may note that the setting of USB keyboard or USB mouse support in the BIOS-setup is only necessary and advisable, if the OS offers no USB-support. BIOS-setup can be changed with a USB keyboard without enabling USB keyboard support. Running Windows with these features enabled may lead to significant performance or functionality limitations. Every USB interface provides up to 500 mA current and is protected by an electronically resettable fuse.

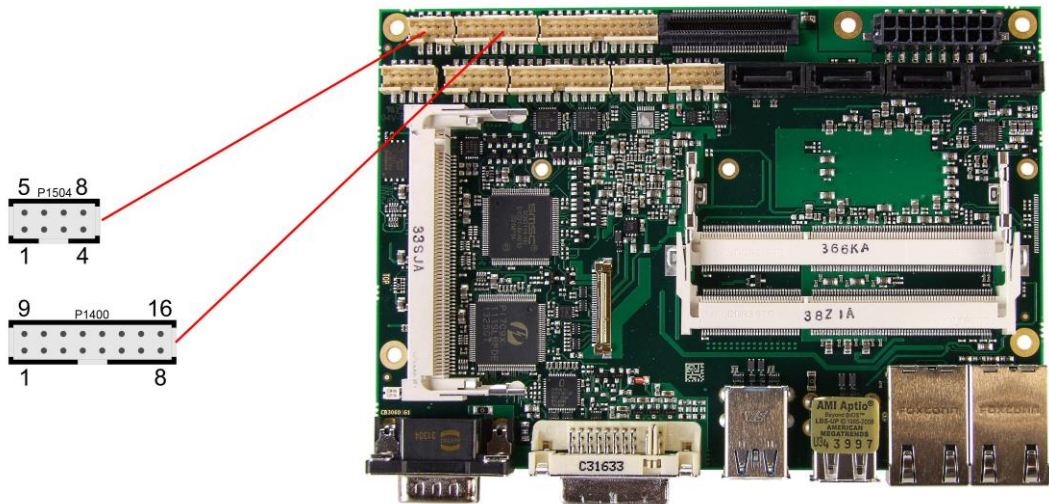

Pinout USB

Description	Name	Pin	Name	Description
5 volt for USB5	VCC	1	9	VCC
minus channel USB5	USB5-	2	10	USB6-
plus channel USB5	USB5+	3	11	USB6+
ground	GND	4	12	GND
ground	GND	5	13	GND
plus channel USB7	USB7+	6	14	USB8+
minus channel USB7	USB7-	7	15	USB8-
5 volt for USB7	VCC	8	16	VCC

Pinout USB 9/10

Description	Name	Pin	Name	Description
5 volt for USB9	VCC	1	5	VCC
minus channel USB9	USB9-	2	6	USB10-
plus channel USB9	USB9+	3	7	USB10+
ground	GND	4	8	GND

3.9 LAN

Both LAN interfaces are provided via a 8pole standard connector (JFM3811F-2101-4F). The interfaces support 10BaseT, 100BaseT, and 1000BaseT compatible network components with automatic bandwidth selection. Additional outputs are provided for status LEDs. Auto-negotiate and auto-cross functionality is available as is PXE and WOL. Controller chips are Intel®'s i218 (PHY, LAN1) and i210 (MAC/PHY, LAN2).

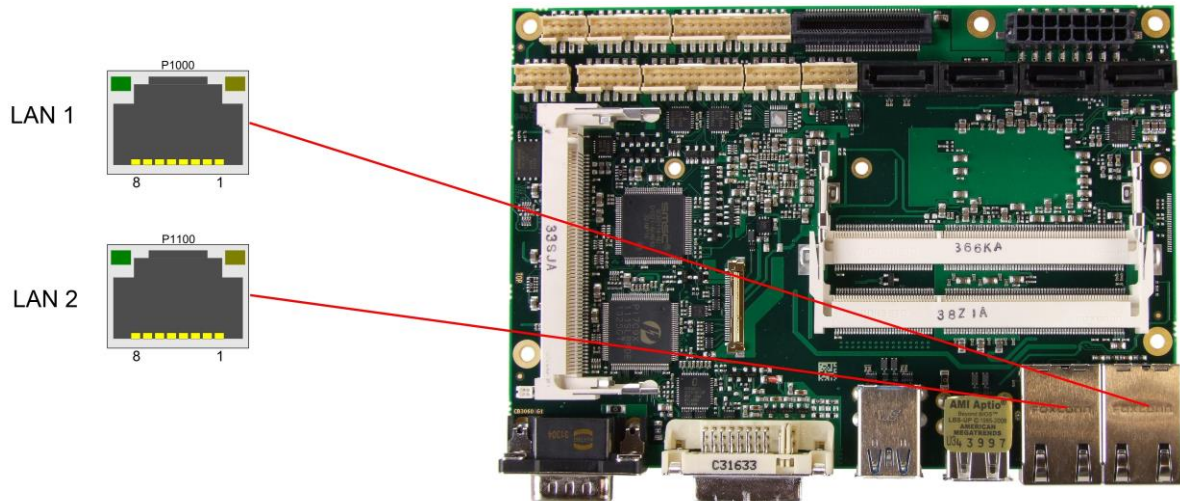

Pinout LAN 10/100/1000:

Pin	Name	Description
1	LAN-0	LAN channel 0 plus
2	LAN-0#	LAN channel 0 minus
3	LAN-1	LAN channel 1 plus
4	LAN-2	LAN channel 2 plus
5	LAN-2#	LAN channel 2 minus
6	LAN-1#	LAN channel 1 minus
7	LAN-3	LAN channel 3 plus
8	LAN-3#	LAN channel 3 minus

3.10 Audio

Audio input and output functions can be accessed via a 2x5 pin connector (FCI 98424-G52-10LF, mating connector FCI 90311-010LF). There are two ways to use this connector. Default functionality is the familiar audio in, audio out, and microphone. OS dependent device drivers can switch these signals to support a 5.1 output; thus in this mode no audio input signals are available. Signals "SPDIFI" and "SPDIFO" provide digital input and output. If a transformation to a coaxial or optical connector is necessary this must be performed externally.

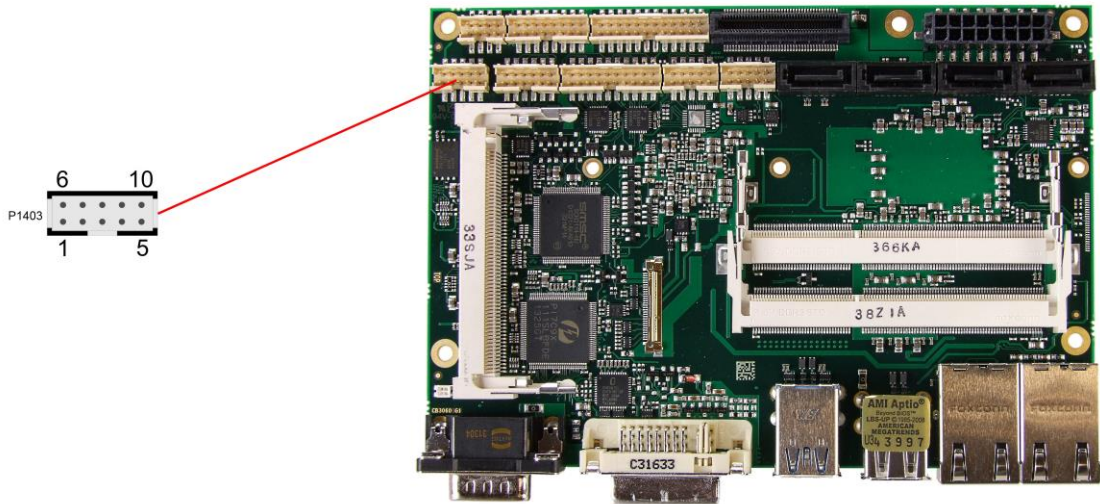

Pinout audio 2x5 pin connector:

Description	Name	Pin		Name	Description
digital output SPDIF	SPDIFO	1	6	3.3V	3.3 volt supply
digital input SPDIF	SPDIFI	2	7	S_AGND	analog ground sound
sound output right / front output right	LOUT_R / FRONT_R	3	8	LOUT_L / FRONT_L	sound output left / front output left
AUX input right / rear output right	AUXA_R / REAR_R	4	9	AUXA_L / REAR_L	AUX input left / rear output left
microphone input 1 / center output	MIC1 / CENTER	5	10	MIC2 / LFE	microphone input 2 / LFE output

3.11 SATA Interfaces

The CB3060 provides four SATA interfaces from which SATA 3 and 4 allow transfer rates of up to 3 Gb/s. Additionally SATA 1 and 2 allow transfer rates up to 6 Gb/s. All these interfaces are made available via a 7pin connector and support RAID 0/1/5/10.

The required settings are made in the BIOS setup.

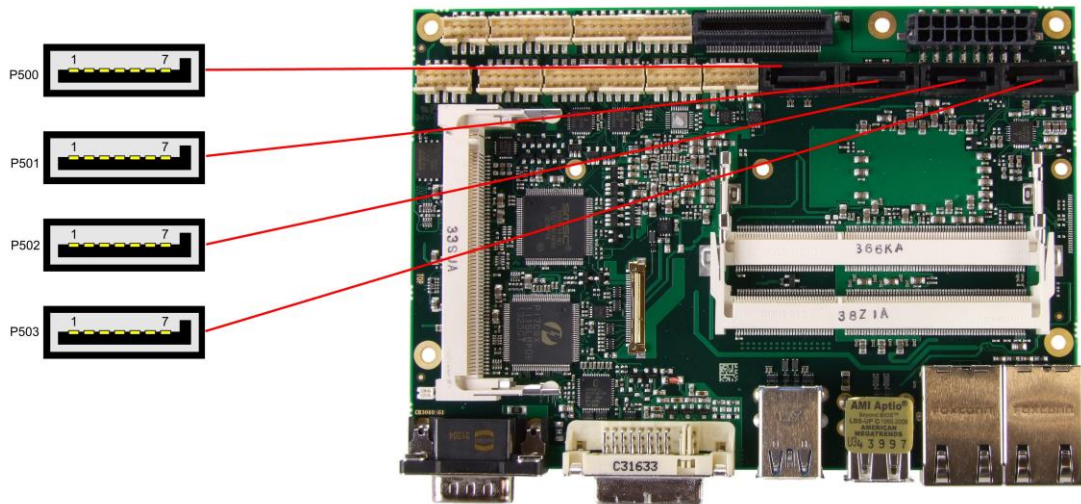

Pinout SATA:

Pin	Name	Description
1	GND	ground
2	SATATX	SATA transmit +
3	SATATX#	SATA transmit -
4	GND	ground
5	SATARX	SATA receive -
6	SATARX#	SATA receive +
7	GND	ground

3.12 Serial Interface COM1

The serial interface COM1 is made available via a 9-pin standard DSUB-contractor (male, e.g. Foxconn DM10152-H5W3-4F). Signal level is RS232. The port address and the interrupt are set via the BIOS setup.

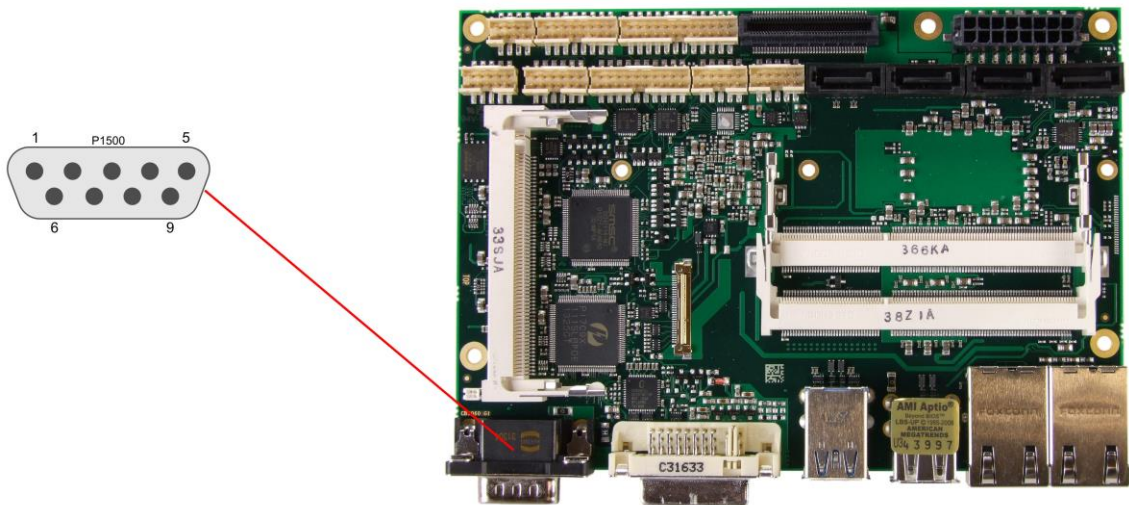

Pinout serial port (DSUB connector):

Description	Name	Pin	Name	Description	
data carrier detect	DCD	1	6	DSR	data set ready
receive data	RXD	2	7	RTS	request to send
transmit data	TXD	3	8	CTS	clear to send
data terminal ready	DTR	4	9	RI	ring indicator
ground	GND	5			

3.13 Serial Ports COM2 through COM4

There are three more serial interfaces on the board. Of these, COM3 is available through the power connector (cf. p. 17), or, as an option, through a 2x5pin connector (FCI 98424-G52-10LF). COM2 and COM4 and made available via a 2x10 pin connector (FCI 98424-G52-20LF). Signal level is RS232. The port address and the interrupt are set via the BIOS setup.

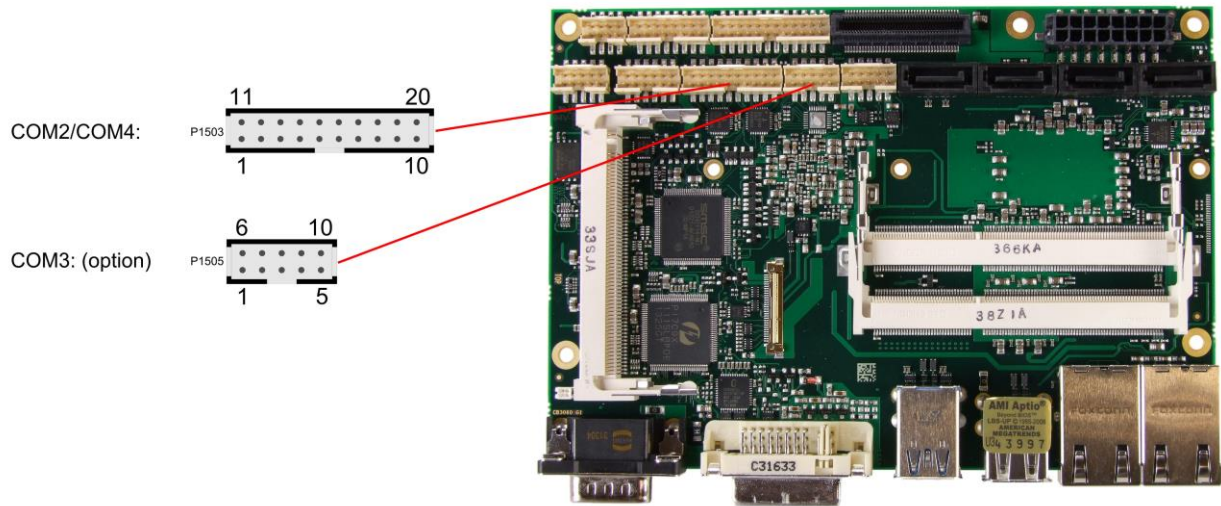

Description	Name	Pin	Name	Description	
data carrier detect COM2	DCDB	1	11	DSRB	data set ready COM2
receive data COM2	RXDB	2	12	RTSB	request to send COM2
transmit data COM2	TXDB	3	13	CTSB	clear to send COM2
data terminal ready COM2	DTRB	4	14	RIB	ring indicator COM2
ground	GND	5	15	SVCC	5 volt supply
data carrier detect COM4	DCDD	6	16	DSRD	data set ready COM4
receive data COM4	RXDD	7	17	RTSD	request to send COM4
transmit data COM4	TXDD	8	18	CTSD	clear to send COM4
data terminal ready COM4	DTRD	9	19	RID	ring indicator COM4
ground	GND	10	20	SVCC	5 volt supply

Description	Name	Pin	Name	Description	
data carrier detect COM3	DCDC	1	6	DSRC	data set ready COM3
receive data COM3	RXDC	2	7	RTSC	request to send COM3
transmit data COM3	TXDC	3	8	CTSC	clear to send COM3
data terminal ready COM3	DTRC	4	9	RIC	ring indicator COM3
ground	GND	5	10	VCC	5 volt supply

When the module is ordered in standard configuration, the 2x5pin connector offers mouse and keyboard signals.

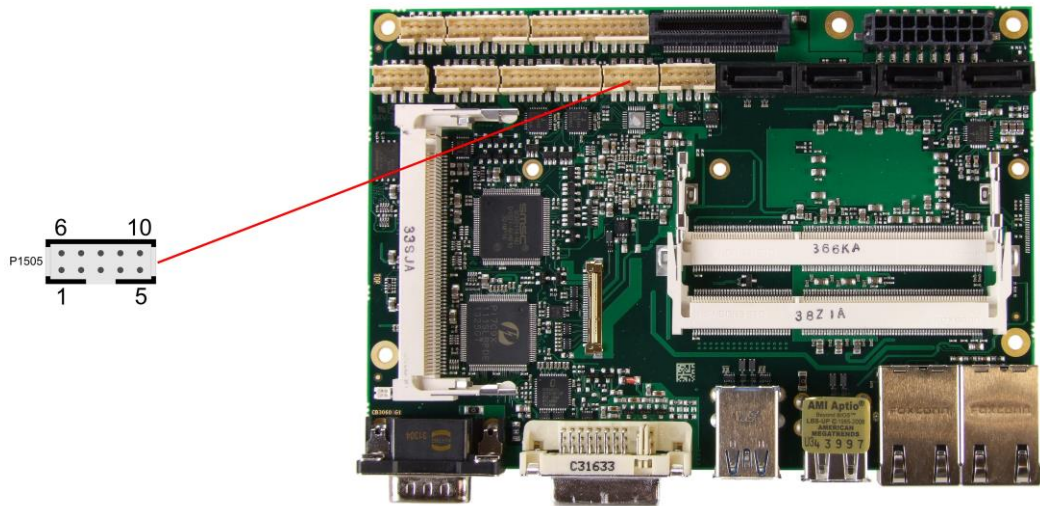

Alternative pinout of COM-connector:

Description	Name	Pin	Name	Description
keyboard clock	KCLK	1	6	MCLK
keyboard data	KDAT	2	7	MDAT
reserved	N/C	3	8	reserved
reserved	N/C	4	9	reserved
ground	GND	5	10	3.3V

3.14 PCI-Express

The CB3060 offers a 2x40pin custom connector for the PCI-Express bus. You can connect one PCIe4x device here. Alternatively, up to four PCIe1x devices can be connected. Adapter cards featuring standard PCIe sockets or a PCIe Mini Card connector are available. Please contact your sales representative for these cards.

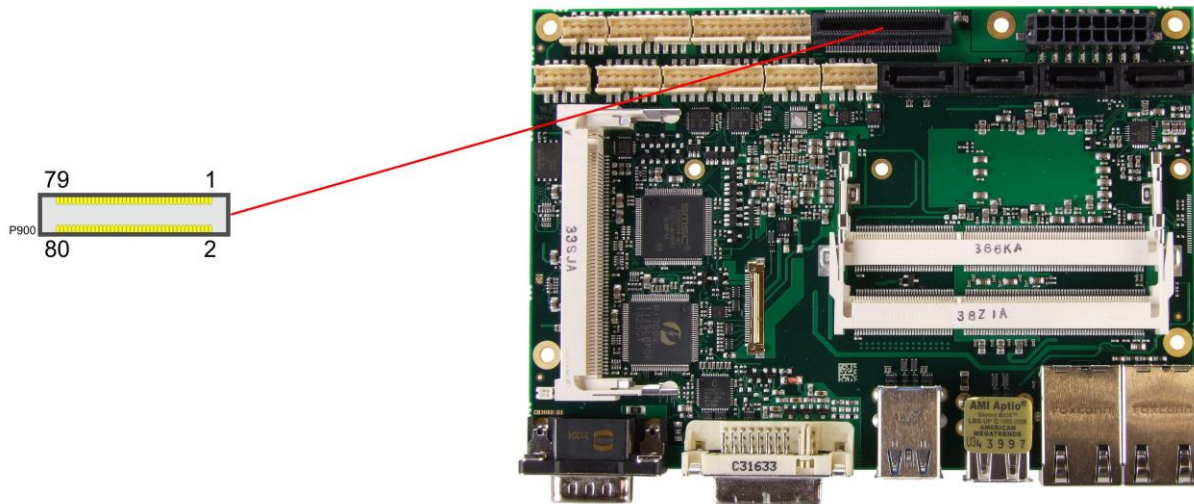

Pinout 2x40 pin connector PCIe:

Description	Name	Pin	Name	Description
3.3 volt supply	3.3V	1	12V	12 volt supply
3.3 volt stand-by	S3.3V	3	SMBCLK1	SMB clock slot 1
PCIe reset	PLTPCIE#	5	SMBDAT1	SMB dat slot 1
link reactivation	PEWAKE#	7	GND	ground
ground	GND	9	REFCLK1	PCIe clock 1 +
transmit lane 1 +	PET1	11	REFCLK1#	PCIe clock 1 -
transmit lane 1 -	PET1#	13	GND	ground
ground	GND	15	PER1	receive lane 1 +
clock enable 1	PE1CLKEN#	17	PER1#	receive lane 1 -
ground	GND	19	GND	ground
3.3 volt supply	3.3V	21	12V	12 volt supply
3.3 volt stand-by	S3.3V	23	SMBCLK2	SMB clock slot 2
PCIe reset	PLTPCIE#	25	SMBDAT2	SMB dat slot 2
link reactivation	PEWAKE#	27	GND	ground
ground	GND	29	REFCLK2	PCIe clock 2 +
transmit lane 2 +	PET2	31	PECLK2#	PCIe clock 2 -
transmit lane 2 -	PET2#	33	GND	ground
ground	GND	35	PER2	receive lane 2 +
clock enable 2	PE2CLKEN#	37	PER2#	receive lane 2 -
ground	GND	39	GND	ground
3.3 volt supply	3.3V	41	12V	12 volt supply
3.3 volt stand-by	S3.3V	43	SMBCLK3	SMB clock slot 3
PCIe reset	PLTPCIE#	45	SMBDAT4	SMB dat slot 3
link reactivation	PEWAKE#	47	GND	ground
ground	GND	49	REFCLK3	PCIe clock 3 +
transmit lane 3 +	PET3	51	PECLK3#	PCIe clock 3 -
transmit lane 3 -	PET3#	53	GND	ground
ground	GND	55	PER3	receive lane 3 +

Description	Name	Pin		Name	Description
clock enable 3	PE3CLKEN#	57	58	PER3#	receive lane 3 -
ground	GND	59	60	GND	ground
3.3 volt supply	3.3V	61	62	12V	12 volt supply
3.3 volt stand-by	S3.3V	63	64	SMBCLK4	SMB clock slot 4
PCIe reset	PLTPCIE#	65	66	SMBDAT4	SMB dat slot 4
link reactivation	PEWAKE#	67	68	GND	ground
ground	GND	69	70	REFCLK4	PCIe clock 4 +
transmit lane 4 +	PET4	71	72	PECLK4#	PCIe clock 4 -
transmit lane 4 -	PET4#	73	74	GND	ground
ground	GND	75	76	PER4	receive lane 4 +
clock enable 4	PE4CLKEN#	77	78	PER4#	receive lane 4 -
PCIe configure x1/x4	PECONF#	79	80	GND	ground

3.15 Mini-PCI

The CB3060 allows you to add expansion cards complying to the Mini-PCI standard (type III). One such card can be inserted into the Mini-PCI slot available on the board.

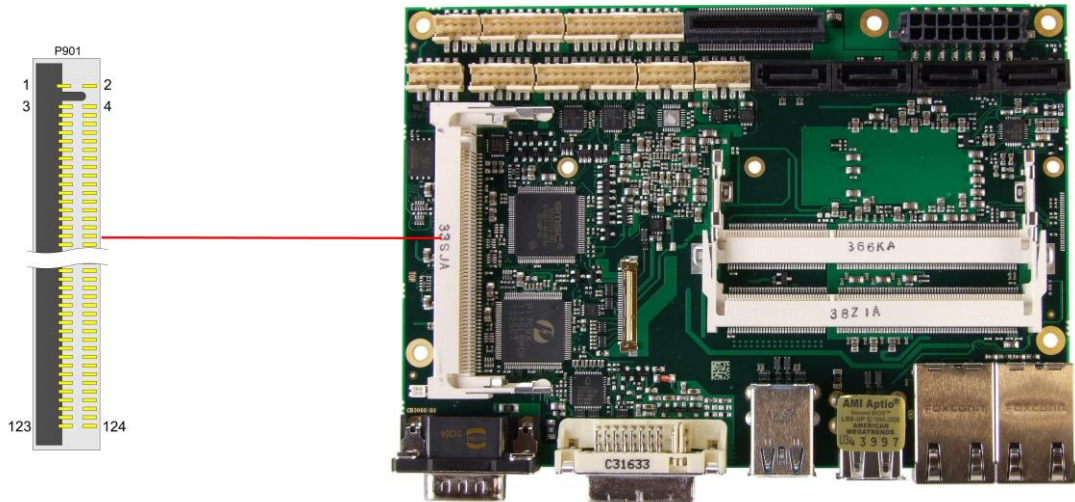

Description	Name	Pin	Pin	Name	Description
reserved	N/C	1	2	N/C	reserved
reserved	N/C	3	4	N/C	reserved
reserved	N/C	5	6	N/C	reserved
reserved	N/C	7	8	N/C	reserved
reserved	N/C	9	10	N/C	reserved
reserved	N/C	11	12	N/C	reserved
reserved	N/C	13	14	N/C	reserved
reserved	N/C	15	16	N/C	reserved
interrupt B	INTB#	17	18	VCC	5 volt supply
3.3 volt supply	3.3V	19	20	INTA#	interrupt A
serial interrupt (legacy)	SERIRQ	21	22	N/C	reserved
ground	GND	23	24	S3.3V	3.3 volt supply
PCI clock	PCLK	25	26	PRST#	reset
ground	GND	27	28	3.3V	3.3 volt supply
PCI request	REQ#	29	30	GNT#	PCI grant
3.3 volt supply	3.3V	31	32	GND	ground
address/data 31	AD31	33	34	PME#	power management event
address/data 29	AD29	35	36	N/C	reserved
ground	GND	37	38	AD30	address/data 30
address/data 27	AD27	39	40	3.3V	3.3 volt supply
address/data 25	AD25	41	42	AD28	address/data 28
interrupt C	INTC#	43	44	AD26	address/data 26
bus cmd/byte enables 3	CBE3#	45	46	AD24	address/data 24
address/data 23	AD23	47	48	IDSEL	init device select
ground	GND	49	50	GND	ground
address/data 21	AD21	51	52	AD22	address/data 22
address/data 19	AD19	53	54	AD20	address/data 20
ground	GND	55	56	PAR	parity
address/data 17	AD17	57	58	AD18	address/data 18
bus cmd/byte enables 2	CBE2#	59	60	AD16	address/data 16

Description	Name	Pin		Name	Description
initiator ready	IRDY#	61	62	GND	ground
3.3 volt supply	3.3V	63	64	FRAME#	cycle frame
clock running	CLKRUN#	65	66	TRDY#	target ready
system error	SERR#	67	68	STOP#	stop request by target
ground	GND	69	70	3.3V	3.3 volt supply
parity error	PERR#	71	72	DEVSEL#	device select
bus cmd/byte enables 1	CBE1#	73	74	GND	ground
address/data 14	AD14	75	76	AD15	address/data 15
ground	GND	77	78	AD13	address/data 13
address/data 12	AD12	79	80	AD11	address/data 11
address/data 10	AD10	81	82	GND	ground
ground	GND	83	84	AD9	address/data 9
address/data 8	AD8	85	86	CBE0#	bus cmd/byte enables 0
address/data 7	AD7	87	88	3.3V	3.3 volt supply
3.3 volt supply	3.3V	89	90	AD6	address/data 6
address/data 5	AD5	91	92	AD4	address/data 4
interrupt D	INTD#	93	94	AD2	address/data 2
address/data 3	AD3	95	96	AD0	address/data 0
5 volt supply	VCC	97	98	N/C	reserved
address/data 1	AD1	99	100	N/C	reserved
ground	GND	101	102	GND	ground
reserved	N/C	103	104	GND	ground
reserved	N/C	105	106	N/C	reserved
reserved	N/C	107	108	N/C	reserved
reserved	N/C	109	110	N/C	reserved
reserved	N/C	111	112	N/C	reserved
reserved	N/C	113	114	GND	ground
reserved	N/C	115	116	N/C	reserved
reserved	N/C	117	118	N/C	reserved
reserved	N/C	119	120	N/C	reserved
lock	PLOCK#	121	122	N/C	reserved
reserved	N/C	123	124	S3.3V	3.3 volt supply

3.16 GPIO

The General Purpose Input/Output interface is made available through a 2x6 pin connector (FCI 98424-G52-12LF, mating connector FCI 90311-012LF). To make use of this interface the GPIO chip (PCA9535BS) must be programmed accordingly. Please refer to your distributor for information on available software support.

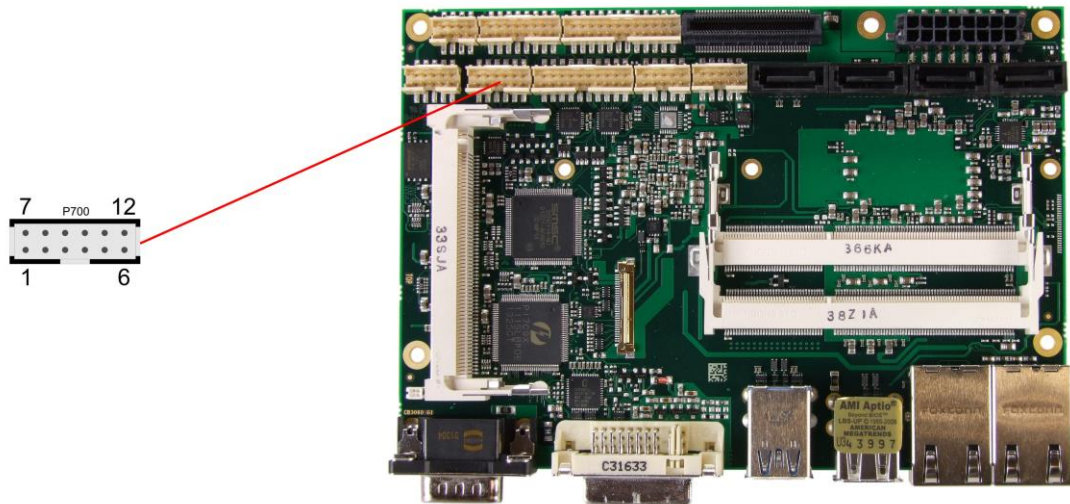

Pinout GPIO connector:

Description	Name	Pin		Name	Description
5 volt supply	VCC	1	7	VCC	5 volt supply
GP input/output 10	GPIO10	2	8	GPIO14	GP input/output 14
GP input/output 11	GPIO11	3	9	GPIO15	GP input/output 15
GP input/output 12	GPIO12	4	10	GPIO16	GP input/output 16
GP input/output 13	GPIO13	5	11	GPIO17	GP input/output 17
ground	GND	6	12	GND	ground

3.17 Fan Connectors

Three external fans (12V) can be connected to the board using a 2x5pin connector (FCI 98424-G52-10LF, mating connector FCI 90311-010LF). Monitoring signals are available. For the monitoring to work the fans must provide a corresponding speed signal.

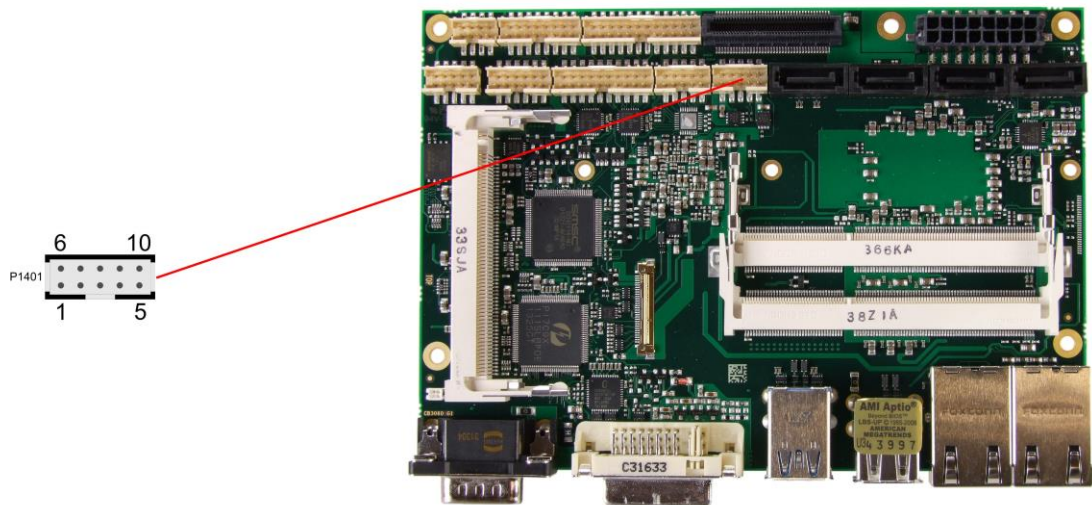

Description	Name	Pin		Name	Description
ground regulated	FANON1	1	6	FANON2	ground regulated
12V supply	12V	2	7	12V	12V supply
Fan 1 monitoring signal	FANCTRL1	3	8	FANCTRL2	Fan 2 monitoring signal
12V supply	12V	4	9	FANCTRL3	Fan 3 monitoring signal
ground regulated	FANON3	5	10	GND	ground

4 State LEDs

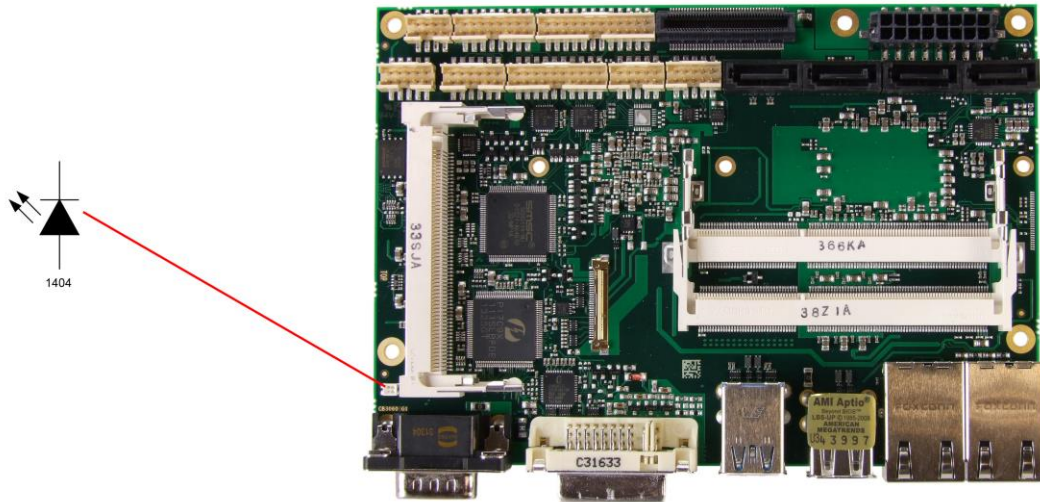

Status Codes RGB LED:

Color	Interval		Meaning	
non	solid		Invalid system state	
White	once		Powerfail	
Cyan	solid		Reserved	
Magenta	solid		if present: SUPS active	
Blue	solid		Reserved	
Yellow	solid		S5 state	
Green	solid		S0 state	
Red	solid		Reset/Start	
Green/Yellow	flashing			Bootloader operates normal
Red/Yellow	flashing			Bootloader is being started (starting sequence still running)
Yellow	flashing (6s)			S4 state
Yellow	flashing (3s)			S3 state
Magenta	flashing (0,5s)			if present: SUPS test of capacity



Notice

Permanently red LED

If the board appears to be in Reset (Red LED lit) then this could also indicate a PCI104-Express "stacking error". Such an error could occur when the stack contains a peripheral card which has the wrong type of connector (PCI104-Express Type 1 instead of Type 2 or vice versa).

5 BIOS Settings

5.1 General Remarks

In each setup page, standard values for all setup entries can be loaded. Previously saved settings are loaded by pressing F2 and factory defaults are loaded with F3. Both F2 and F3, and also F4 ("Save & Exit") always affect the whole set of setup entries.

Setup entries starting with a „►" sign represent submenus. Navigation between entries is done using the arrow keys on the keyboard, with the <Enter> key being used to select an entry, which either opens up a dialog box or opens a whole new submenu of setup entries.

Each setup entry has a short help text associated with it. This is displayed in the upper right hand corner of the screen.



Notice

BIOS features and setup options are subject to change without notice. The settings displayed in the screenshots on the following pages are meant to be examples only. They do not represent the recommended settings or the default settings. Determination of the appropriate settings is dependent upon the particular application scenario in which the board is used.

5.2 Main

Aptio Setup Utility - Copyright (C) 2012 American Megatrends, Inc.
 MAIN Advanced Chipset Boot Security Save & Exit

<pre> Board Information Board CB3060 Revision 1 Bios Version 0.33 Processor Information Name Haswell Brand String Intel(R) Core(TM) i3-410 Frequency 2400MHz Processor ID 306c3 Stepping C0 Number of Processors 2Core(s) / 2Thread(s) Microcode Revision 17 GT Info GT2 (800 MHz) IGFX VBIOS Version 2179 Memory RC Version 1.6.2.1 Total Memory 8192 MB (DDR3) Memory Frequency 1600 Mhz System Date [Thu 19/03/2014] System Time [00:47:04] </pre>	<pre> Set the Date. Use Tab to switch between Data elements. ---: Select Screen ↑↓: Select Item Enter: Select +/-: Change Opt. F1: General Help F2: Previous Values F3: Optimized Defaults F4: Save & Exit ESC: Exit </pre>
--	--

Version 2.15.1236. Copyright (C) 2012 American Megatrends, Inc.

- ✓ **Board**
Options: none
- ✓ **Revision**
Options: none
- ✓ **Bios Version**
Options: none
- ✓ **Processor Information**
Options: none
- ✓ **Name**
Options: none
- ✓ **Brand String**
Options: none
- ✓ **Frequency**
Options: none
- ✓ **Processor ID**
Options: none
- ✓ **Stepping**
Options: none
- ✓ **Number of Processors**
Options: none
- ✓ **Microcode Revision**
Options: none
- ✓ **GT Info**
Options: none

- ✓ **IGFX VBIOS Version**
Options: none
- ✓ **Memory RC Version**
Options: none
- ✓ **Total Memory**
Options: none
- ✓ **Memory Frequency**
Options: none
- ✓ **System Date**
Options: The system date can be adjusted here.
- ✓ **System Time**
Options: The system time can be adjusted here.

5.3 Advanced

Aptio Setup Utility - Copyright (C) 2012 American Megatrends, Inc.
Main ADVANCED Chipset Boot Security Save & Exit

Power-Supply Type [ATX] SoftOff on Overheat [Disabled] ▶ PCI Subsystem Settings ▶ ACPI Settings ▶ Trusted Computing ▶ CPU Configuration ▶ SATA Configuration ▶ AMT Configuration ▶ Power Controller Options ▶ USB Configuration ▶ Super IO Configuration ▶ H/W Monitor ▶ Serial Port Console Redirection ▶ Network Stack ▶ Intel(R) Ethernet Connection I218-LM - 88:88:88:88:87:88 ▶ Intel(R) I210 Gigabit Network Connection - 00:01:05:14:... ▶ Driver Health	Select the Type of the Power Supply: AT/ATX
	←: Select Screen ↑↓: Select Item Enter: Select +/-: Change Opt. F1: General Help F2: Previous Values F3: Optimized Defaults F4: Save & Exit ESC: Exit

Version 2.15.1236. Copyright (C) 2012 American Megatrends, Inc.

- ✓ **Power-Supply Type**
Options: ATX / AT
- ✓ **SoftOff on Overheat**
Options: Disabled / Enabled
- ✓ **PCI Subsystem Settings**
Sub menu: see "PCI Subsystem Settings" (page 46)
- ✓ **ACPI Settings**
Sub menu: see "ACPI Settings" (page 48)
- ✓ **Trusted Computing**
Sub menu: see "Trusted Computing" (page 49)
- ✓ **CPU Configuration**
Sub menu: see "CPU Configuration" (page 50)
- ✓ **SATA Configuration**
Sub menu: see "SATA Configuration" (page 53)
- ✓ **AMT Configuration**
Sub menu: see "AMT Configuration" (page 56)
- ✓ **Power Controller Options**
Sub menu: see "Power Controller Options" (page 58)
- ✓ **USB Configuration**
Sub menu: see "USB Configuration" (page 60)
- ✓ **Super IO Configuration**
Sub menu: see "Super IO Configuration" (page 61)
- ✓ **H/W Monitor**
Sub menu: see "H/W Monitor" (page 63)

- ✓ **Serial Port Console Redirection**
Sub menu: see "Serial Port Console Redirection" (page 65)
- ✓ **Network Stack**
Sub menu: see "Network Stack" (page 68)
- ✓ **Intel(R) Ethernet Connection I218**
Sub menu: see "Intel(R) Ethernet Connection I218-LM" (page 69)
- ✓ **Driver Health**
Sub menu: see "Driver Health" (page 73)

5.3.1 PCI Subsystem Settings

Aptio Setup Utility - Copyright (C) 2012 American Megatrends, Inc.
Advanced

PCI Bus Driver Version	V 2.05.02	Value to be programmed into PCI Latency Timer Register.
PCI Common Settings		
PCI Latency Timer	[32 PCI Bus Clocks]	
▶ PCI Express Settings		
		←: Select Screen ↑↓: Select Item Enter: Select +/-: Change Opt. F1: General Help F2: Previous Values F3: Optimized Defaults F4: Save & Exit ESC: Exit

Version 2.15.1236. Copyright (C) 2012 American Megatrends, Inc.

- ✓ **PCI Latency Timer**
Options: 32, 64,...224, 248 PCI Bus Clocks
- ✓ **PCI Express Settings**
Sub menu: see "PCI Express Settings" (page 47)

5.3.2 ACPI Settings

Aptio Setup Utility - Copyright (C) 2012 American Megatrends, Inc.
Advanced

ACPI Settings		Enables or Disables BIOS ACPI Auto Configuration.
Enable ACPI Auto Configuration	[Disabled]	
Enable Hibernation	[Enabled]	
ACPI Sleep State	[S1 only(CPU Stop Cl...)]	
Lock Legacy Resources	[Disabled]	
		←: Select Screen ↑↓: Select Item Enter: Select +/-: Change Opt. F1: General Help F2: Previous Values F3: Optimized Defaults F4: Save & Exit ESC: Exit

Version 2.15.1236. Copyright (C) 2012 American Megatrends, Inc.

- ✓ **Enable ACPI Auto Configuration**
Options: Enabled / Disabled
- ✓ **Enable Hibernation**
Options: Enabled / Disabled
- ✓ **ACPI Sleep State**
Options: Suspend Disabled / S1 (CPU Stop Clock)
- ✓ **Lock Legacy Resources**
Options: Enabled / Disabled

5.3.3 Trusted Computing

Aptio Setup Utility - Copyright (C) 2012 American Megatrends, Inc.
Advanced

<pre> Configuration Security Device Support [Disabled] Current Status Information NO Security Device Found </pre>	<pre> Enables or Disables BIOS support for security device. O.S. will not show Security Device. TCG EFI protocol and INT1A interface will not be available. ----- ->: Select Screen ↑↓: Select Item Enter: Select +/-: Change Opt. F1: General Help F2: Previous Values F3: Optimized Defaults F4: Save & Exit ESC: Exit </pre>
---	--

Version 2.15.1236. Copyright (C) 2012 American Megatrends, Inc.

- ✓ **Security Device Support**
Options: Enabled / Disabled

5.3.4 CPU Configuration

Aptio Setup Utility - Copyright (C) 2012 American Megatrends, Inc.
Advanced

CPU Configuration		▲ Enabled for Windows XP and Linux (OS optimized for Hyper-Threading Technology) and Disabled for other OS (OS not optimized for Hyper-Threading Technology). When Disabled only one thread per enabled core is enabled. →: Select Screen ↑↓: Select Item Enter: Select +/-: Change Opt. F1: General Help F2: Previous Values F3: Optimized Defaults F4: Save & Exit ESC: Exit
Intel(R) Core(TM) i3-4100E CPU @ 2.40GHz		
CPU Signature	306c3	
Processor Family	6	
Microcode Patch	16	
FSB Speed	100 MHz	
Max CPU Speed	2400 MHz	
Min CPU Speed	800 MHz	
CPU Speed	2400 MHz	
Processor Cores	4	
Intel HT Technology	Not Supported	
Intel VT-x Technology	Supported	
Intel SMX Technology	Not Supported	
64-bit	Supported	
EIST Technology	Supported	
CPU C3 State	Supported	
CPU C6 State	Supported	
CPU C7 State	Supported	
L1 Data Cache	32 kB x 2	
L1 Code Cache	32 kB x 2	
L2 Cache	256 kB x 2	
L3 Cache	3072 kB	

Version 2.15.1236. Copyright (C) 2012 American Megatrends, Inc.

- ✓ **CPU Signature**
Options: none
- ✓ **Processor Family**
Options: none
- ✓ **Microcode Patch**
Options: none
- ✓ **FSB Speed**
Options: none
- ✓ **Max CPU Speed**
Options: none
- ✓ **Min CPU Speed**
Options: none
- ✓ **CPU Speed**
Options: none
- ✓ **Processor Cores**
Options: none
- ✓ **Intel HT Technology**
Options: none
- ✓ **Intel VT-x Technology**
Options: none
- ✓ **Intel SMX Technology**
Options: none

-
- ✓ **64-bit**
Options: none
 - ✓ **EIST Technology**
Options: none
 - ✓ **CPU C3 state**
Options: none
 - ✓ **CPU C6 state**
Options: none
 - ✓ **CPU C7 state**
Options: none
 - ✓ **L1 Data Cache**
Options: none
 - ✓ **L1 Code Cache**
Options: none
 - ✓ **L2 Cache**
Options: none
 - ✓ **L3 Cache**
Options: none
 - ✓ **Hyper-threading**
Options: Enabled / Disabled
 - ✓ **Active Processor Cores**
Options: All
 - ✓ **Overclocking lock**
Options: Disabled / Enabled
 - ✓ **Limit CPUID Maximum**
Options: Enabled / Disabled
 - ✓ **Execute Disable Bit**
Options: Enabled / Disabled
 - ✓ **Intel Virtualization Technology**
Options: Enabled / Disabled
 - ✓ **Hardware Prefetcher**
Options: Disabled / Enabled
 - ✓ **Adjacent Cache Line Prefetch**
Options: Disabled / Enabled
 - ✓ **EIST**
Options: Disabled / Enabled
 - ✓ **Turbo Mode**
Options: Enabled / Disabled
 - ✓ **Package power limit lock**
Options: Disabled / Enabled

-
- ✓ **CPU Power Limit1**
Options: 0..255
 - ✓ **CPU Power Limit1 Time**
Options: 0..255
 - ✓ **CPU Power Limit 2**
Options: 0..255
 - ✓ **Platform power limit lock**
Options: Disabled / Enabled
 - ✓ **CPU Power Limit3**
Options: 0..255
 - ✓ **CPU Power Limit3 Time**
Options: 0..255
 - ✓ **CPU Power Limit3 Duty Cycle**
Options: 0..100
 - ✓ **DDR Power Limit1**
Options: 0..255
 - ✓ **DDR Power Limit1 Time**
Options: 0..255
 - ✓ **DDR Power Limit2**
Options: 0..255
 - ✓ **1-Core Ratio Limit**
Options: 0..255
 - ✓ **2-Core Ratio Limit**
Options: 0..255
 - ✓ **TCC Activation Offset**
Options: 0...15
 - ✓ **ACPI T State**
Options: Disabled / Enabled
 - ✓ **CPU DTS**
Options: Disabled / Enabled

5.3.5 SATA Configuration

Aptio Setup Utility - Copyright (C) 2012 American Megatrends, Inc.
Advanced

SATA Controller(s)	[Enabled]	▲ Enable or disable SATA Device.
SATA Mode Selection	[RAID]	
SATA Test Mode	[Disabled]	
SATA Controller Speed	[Default]	
▶ Software Feature Mask Configuration		
Alternate ID	[Disabled]	
Serial ATA Port 0	Empty	
Software Preserve	Unknown	
Port 0	[Enabled]	
Hot Plug	[Disabled]	
External SATA	[Disabled]	
SATA Device Type	[Hard Disk Drive]	
Spin Up Device	[Disabled]	
Serial ATA Port 1	Empty	←: Select Screen
Software Preserve	Unknown	↑↓: Select Item n
Port 1	[Inabled]	Enter: Select
Hot Plug	[Disabled]	+/-: Change Opt.
External SATA	[Disabled]	F1: General Help
SATA Device Type	[Hard Disk Drive]	F2: Previous Values
Spin Up Device	[Disabled]	F3: Optimized Defaults
Serial ATA Port 2	Empty	F4: Save & Exit
Software Preserve	Unknown	ESC: Exit
Port 2	[Enabled]	
Hot Plug	[Disabled]	
External SATA	[Disabled]	
SATA Device Type	[Hard Disk Drive]	

Version 2.15.1236. Copyright (C) 2012 American Megatrends, Inc.

- ✓ **SATA Controller(s)**
Options: Enabled / Disabled
- ✓ **SATA Mode Selection**
Options: IDE / AHCI / RAID
- ✓ **SATA Test Mode**
Options: Enabled / Disabled
- ✓ **SATA Controller Speed**
Options: Default / Gen1 / Gen2 / Gen3
- ✓ **Software Feature Mask Configuration**
Sub menu: see "Software Feature Mask Configuration" (page 55)
- ✓ **Alternate ID**
Options: Enabled / Disabled
- ✓ **Serial ATA Port X**
Options: none
- ✓ **Software Preserve**
Options: none
- ✓ **Port X**
Options: Enabled / Disabled
- ✓ **Hot Plug**
Options: Enabled / Disabled
- ✓ **Mechanical Presence Switch**
Options: Disabled / Enabled

- ✓ **External SATA**
Options: Enabled / Disabled
- ✓ **SATA Device Type**
Options: Hard Disk Drive / Solid State Drive
- ✓ **Spin Up Device**
Options: Enabled / Disabled

5.3.5.1 Software Feature Mask Configuration

Aptio Setup Utility - Copyright (C) 2012 American Megatrends, Inc.
Advanced

RAID0	[Enabled]	Enable or disable RAID0 feature.
RAID1	[Enabled]	
RAID10	[Enabled]	
RAID5	[Enabled]	
Intel Rapid Recovery Technology	[Enabled]	
OROM UI and BANNER	[Enabled]	
HDD Unlock	[Enabled]	
LED Locate	[Enabled]	
IRRT Only on eSATA	[Enabled]	
Smart Response Technology	[Enabled]	
OROM UI Delay	[2 Seconds]	
		←: Select Screen ↑: Select Item Enter: Select +/-: Change Opt. F1: General Help F2: Previous Values F3: Optimized Defaults F4: Save & Exit ESC: Exit

Version 2.15.1236. Copyright (C) 2012 American Megatrends, Inc.

- ✓ **RAID0**
Options: Enabled / Disabled
- ✓ **RAID1**
Options: Enabled / Disabled
- ✓ **RAID10**
Options: Enabled / Disabled
- ✓ **RAID5**
Options: Enabled / Disabled
- ✓ **Intel Rapid Recovery Technology**
Options: Enabled / Disabled
- ✓ **OROM UI and BANNER**
Options: Enabled / Disabled
- ✓ **HDD Unlock**
Options: Enabled / Disabled
- ✓ **LED Locate**
Options: Enabled / Disabled
- ✓ **IRRT Only on eSATA**
Options: Enabled / Disabled
- ✓ **Smart Response Technology**
Options: Enabled / Disabled
- ✓ **OROM UI Delay**
Options: 2 / 4 / 6 / 8 Seconds

5.3.6 AMT Configuration

Aptio Setup Utility - Copyright (C) 2012 American Megatrends, Inc.
Advanced

Intel AMT	[Disabled]	Enable/Disabled Intel (R) Active Management Technology BIOS Extension. Note : iAMT H/W is always enabled. This option just controls the BIOS extension execution. If enabled, this requires additional firmware in the SPI device
BIOS Hotkey Pressed	[Disabled]	
MEBx Selection Screen	[Disabled]	
Hide Un-Configure ME Confirmation	[Disabled]	
MEBx Debug Message Output	[Disabled]	
Un-Configure ME	[Disabled]	
Amt Wait Timer	0	
Disable ME	[Disabled]	
ASF	[Enabled]	
Activate Remote Assistance Process	[Disabled]	
USB Configure	[Enabled]	
PET Progress	[Enabled]	
AMT CIRA Timeout	0	
Watchdog	[Disabled]	
OS Timer	0	
BIOS Timer	0	

Version 2.15.1236. Copyright (C) 2012 American Megatrends, Inc.

- ✓ **Intel AMT**
Options: Disabled / Enabled
- ✓ **BIOS Hotkey Pressed**
Options: Disabled / Enabled
- ✓ **MEBx Selection Screen**
Options: Disabled / Enabled
- ✓ **Hide Un-Configure ME Configuration**
Options: Disabled / Enabled
- ✓ **MEBx Debug Message Output**
Options: Disabled / Enabled
- ✓ **Un-Configure ME**
Options: Disabled / Enabled
- ✓ **Amt Wait Timer**
Options: none
- ✓ **Disable ME**
Options: Disabled / Enabled
- ✓ **ASF**
Options: Disabled / Enabled
- ✓ **Activate Remote Assistance Process**
Options: Disabled / Enabled
- ✓ **USB Configure**
Options: Disabled / Enabled
- ✓ **PET Progress**
Options: Disabled / Enabled

- ✓ **AMT CIRA Timeout**
Options: none
- ✓ **Watchdog**
Options: Disabled / Enabled
- ✓ **OS Timer**
Options: none
- ✓ **BIOS Timer**
Options: none

5.3.7 Power Controller Options

Aptio Setup Utility - Copyright (C) 2012 American Megatrends, Inc.
Advanced

Bootloader Version	1.00-23	Select Power line for external USB devices, if powered-down
Firmware Version	1.00-43	
Mainboard Serial No	11473413400016	
Mainboard Prod. Date (Week.Year)	4.14	
Mainboard BootCount	254	
Mainboard Operation Time	45555min (759h)	
Voltage (Min/Max)	4.30V / 4.70V	
Temperature (Min/Max)	26'C /33'C	
ext. USB-Port Voltage	[Off in S3-5]	
int. USB-Port Voltage	[Off in S3-5]	
WatchDogTimer Mode	[Normal Mode]	
WDT OSBoot Timeout	[Disabled]	

Version 2.15.1236. Copyright (C) 2012 American Megatrends, Inc.

- ✓ **Bootloader Version**
Options: none
- ✓ **Firmware Version**
Options: none
- ✓ **Mainboard Serial No**
Options: none
- ✓ **Mainboard Prod. Date (Week.Year)**
Options: none
- ✓ **Boot Count**
Options: none
- ✓ **Minute Meter**
Options: none
- ✓ **Voltage (Min/Max)**
Options: none
- ✓ **Temperature (Min/Max)**
Options: none
- ✓ **ext. USB-Port Voltage**
Options: Off in S3-5 / by SVCC
- ✓ **int. USB-Port Voltage**
Options: Off in S3-5 / by SVCC
- ✓ **WatchDogTimer Mode**
Options: Normal Mode / Compatibility Mode

✓ **WDT OSBoot Timeout**

Options: Disabled / 45 Seconds ... 255 Seconds

5.3.8 USB Configuration

Aptio Setup Utility - Copyright (C) 2012 American Megatrends, Inc.
Advanced

<pre> USB Configuration USB Module Version 8.10.27 USB Devices: 1 Keyboard, 2 Hubs Legacy USB Support [Auto] USB3.0 Support [Enabled] XHCI Hand-off [Enabled] EHCI Hand-off [Disabled] USB hardware delays and time-outs: USB transfer time-out [5 sec] Device reset time-out [10 sec] Device power-up delay [Manual] Device power-up delay in seconds 5 </pre>	<pre> Enables Legacy USB support. AUTO option disables legacy support if no USB devices are connected. DISABLE option will keep USB devices available only for EFI applications. ----- ←: Select Screen ↑↓: Select Item Enter: Select +/-: Change Opt. F1: General Help F2: Previous Values F3: Optimized Defaults F4: Save & Exit ESC: Exit </pre>
--	--

Version 2.15.1236. Copyright (C) 2012 American Megatrends, Inc.

- ✓ **USB Module Version**
Options: none
- ✓ **USB Devices**
Options: none
- ✓ **Legacy USB Support**
Options: Enabled / Disabled / Auto
- ✓ **USB3.0 Support**
Options: Enabled / Disabled
- ✓ **XHCI Hand-off**
Options: Enabled / Disabled
- ✓ **EHCI Hand-off**
Options: Enabled / Disabled
- ✓ **USB transfer time-out**
Options: 5 sec / 10 sec / 20 sec
- ✓ **Device reset time-out**
Options: 10 sec / 20 sec / 30 sec / 40 sec
- ✓ **Device power-up delay**
Options: Auto / Manual
- ✓ **Device power-up delay in seconds**
Options: 1..40

5.3.9 Super IO Configuration

Aptio Setup Utility - Copyright (C) 2012 American Megatrends, Inc.
Advanced

<pre> Super IO Configuration Super IO Chip SMSC SCH3114 ▶ Serial Port 0 Configuration ▶ Serial Port 1 Configuration ▶ Serial Port 2 Configuration ▶ Serial Port 3 Configuration </pre>	<pre> Set Parameters of Serial Port 0 (COMA) ----- ←: Select Screen ↑↓: Select Item Enter: Select +/-: Change Opt. F1: General Help F2: Previous Values F3: Optimized Defaults F4: Save & Exit ESC: Exit </pre>
---	---

Version 2.15.1236. Copyright (C) 2012 American Megatrends, Inc.

- ✓ **Super IO Chip**
Options: none
- ✓ **Serial Port X Configuration**
Sub menu: see "Serial Port Configuration" (page 62)

5.3.9.1 Serial Port Configuration

Aptio Setup Utility - Copyright (C) 2012 American Megatrends, Inc.
Advanced

Serial Port 0 Configuration		Enable or Disable Serial Port (COM)
Serial Port	[Enabled]	
Device Settings	IO=3F8h; IRQ=4;	
Change Settings	[Auto]	
Device Mode	[Normal]	
		←: Select Screen ↑: Select Item Enter: Select +/-: Change Opt. F1: General Help F2: Previous Values F3: Optimized Defaults F4: Save & Exit ESC: Exit

Version 2.15.1236. Copyright (C) 2012 American Megatrends, Inc.

- ✓ **Serial Port**
Options: Enabled / Disabled
- ✓ **Device Settings**
Options: none
- ✓ **Change Settings**
Options: Auto / IO=3F8h; IRQ=4 / IO=3F8h; IRQ=3, ...12 / IO=2F8h; IRQ=3, ...12 / IO=3E8h; IRQ=3, ...12 / IO=2E8h; IRQ=3, ...12
- ✓ **Device Mode**
Options: Normal / High Speed

5.3.10 H/W Monitor

Aptio Setup Utility - Copyright (C) 2012 American Megatrends, Inc.
Advanced

H/W Monitor		
CPU Temperature	: +67'C	
Board Temperature	: +32'C	
Memory Temperature	: +28'C	
SYS FAN Speed	: N/A	
CPU FAN Speed	: 2333 RPM	
AUX FAN Speed	: N/A	
+1.05V	: +1.02 V	
VccCore	: +1.74 V	
+3.3V	: +3.22 V	
Vcc	: +4.97 V	
+12V	: +12.17 V	
VTR	: +3.40 V	
Vbat	: +0.5 V	
		←: Select Screen ↑↓: Select Item Enter: Select +/-: Change Opt. F1: General Help F2: Previous Values F3: Optimized Defaults F4: Save & Exit ESC: Exit

Version 2.15.1236. Copyright (C) 2012 American Megatrends, Inc.

- ✓ **CPU Temperature**
Options: none
- ✓ **Board Temperature**
Options: none
- ✓ **Memory Temperature**
Options: none
- ✓ **SYS FAN Speed**
Options: none
- ✓ **CPU FAN Speed**
Options: none
- ✓ **AUX FAN Speed**
Options: none
- ✓ **+1.05V**
Options: none
- ✓ **VccCore**
Options: none
- ✓ **+3.3V**
Options: none
- ✓ **Vcc**
Options: none
- ✓ **+12V**
Options: none

- ✓ **VTR**
Options: none

- ✓ **Vbat**
Options: none

5.3.11 Serial Port Console Redirection

Aptio Setup Utility - Copyright (C) 2012 American Megatrends, Inc.
Advanced

COM0 Console Redirection [Disabled] ▶ Console Redirection Settings	Console Redirection Enable or Disable.
COM1 Console Redirection [Disabled] ▶ Console Redirection Settings	
COM2 Console Redirection [Disabled] ▶ Console Redirection Settings	
COM3 Console Redirection [Disabled] ▶ Console Redirection Settings	
←: Select Screen ↑↓: Select Item Enter: Select +/-: Change Opt. F1: General Help F2: Previous Values F3: Optimized Defaults F4: Save & Exit ESC: Exit	

Version 2.15.1236. Copyright (C) 2012 American Megatrends, Inc.

- ✓ **Console Redirection**
Options: Enabled / Disabled
- ✓ **Console Redirection Settings**
Sub menu: see "Console Redirection Settings" (page 66)

5.3.11.1 Console Redirection Settings

Aptio Setup Utility - Copyright (C) 2012 American Megatrends, Inc.
Advanced

COM0 Console Redirection Settings Terminal Type [VT-UTF8] Bits per second [115200] Data Bits [8] Parity [None] Stop Bits [1] Flow Control [None] VT-UTF8 Combo Key Support [Enabled] Recorder Mode [Disabled] Resolution 100x31 [Enabled] Legacy OS Redirection Resolution [80x24] Putty KeyPad [VT100] Redirection After BIOS POST [Always Enable]	Emulation: ANSI: Extended ASCII char set. VT100: ASCII char set. VT100+: Extends VT100 to support color, function keys, etc. VT-UTF8: Uses UTF8 encoding to map Unicode chars onto 1 or more bytes. ←: Select Screen ↑: Select Item Enter: Select +/-: Change Opt. F1: General Help F2: Previous Values F3: Optimized Defaults F4: Save & Exit ESC: Exit
--	--

Version 2.15.1236. Copyright (C) 2012 American Megatrends, Inc.

- ✓ **Terminal Type**
Options: VT100 / VT100+ / VT-UTF8 / ANSI
- ✓ **Bits per second**
Options: 9600 / 19200 / 38400 / 57600 / 115200
- ✓ **Data Bits**
Options: 7 / 8
- ✓ **Parity**
Options: None / Even / Odd / Mark / Space
- ✓ **Stop Bits**
Options: 1 / 2
- ✓ **Flow Control**
Options: None / Hardware RTS/CTS
- ✓ **VT-UTF8 Combo Key Support**
Options: Disabled / Enabled
- ✓ **Recorder Mode**
Options: Disabled / Enabled
- ✓ **Resolution 100x31**
Options: Disabled / Enabled
- ✓ **Legacy OS Redirection Resolution**
Options: 80x24 / 80x25
- ✓ **Putty KeyPad**
Options: VT100 / LINUX / XTERMR6 / SCO / ESCN / VT400

- ✓ **Redirection After BIOS POST**
Options: Always Enable / BootLoader

5.3.12 Network Stack

Aptio Setup Utility - Copyright (C) 2012 American Megatrends, Inc.
Advanced

Network stack	[Enabled]	Enable/Disable UEFI network stack
IPv4 PXE Support	[Enabled]	
IPv6 PXE Support	[Enabled]	
		→: Select Screen ↑↓: Select Item Enter: Select +/-: Change Opt. F1: General Help F2: Previous Values F3: Optimized Defaults F4: Save & Exit ESC: Exit

Version 2.15.1236. Copyright (C) 2012 American Megatrends, Inc.

- ✓ **Network stack**
Options: Disabled / Enabled
- ✓ **IPv4 PXE Support**
Options: Disabled / Enabled
- ✓ **IPv6 PXE Support**
Options: Disabled / Enabled

5.3.13 Intel(R) Ethernet Connection I218-LM

Aptio Setup Utility - Copyright (C) 2012 American Megatrends, Inc.
Advanced

<pre> PORT CONFIGURATION MENU ▶ NIC Configuration Blink LEDs 0 PORT CONFIGURATION INFORMATION UEFI Driver: Intel(R) PRO/1000 5.7.06 Adapter PBA: FFFFFFF-0FF Chip Type Intel PCH LPT PCI Device ID 153A Bus:Device:Function 00:19:00 Link Status [Disconnected] MAC Address 88:88:88:88:87:88 </pre>	<p>Configure Boot Protocol, Wake on LAN, Link Speed, and VLAN</p> <hr/> <pre> ←: Select Screen ↑↓: Select Item Enter: Select +/-: Change Opt. F1: General Help F2: Previous Values F3: Optimized Defaults F4: Save & Exit ESC: Exit </pre>
---	--

Version 2.15.1236. Copyright (C) 2012 American Megatrends, Inc.

- ✓ **NIC Configuration**
Sub menu: see "NIC Configuration" (page 70)
- ✓ **Blink LEDs**
Options: none
- ✓ **UEFI Driver:**
Options: none
- ✓ **Adapter PBA:**
Options: none
- ✓ **Chip Type**
Options: none
- ✓ **PCI Device ID**
Options: none
- ✓ **PCI Bus:Device:Function**
Options: none
- ✓ **Link Status**
Options: none
- ✓ **Factory MAC Adress**
Options: none

5.3.13.1 NIC Configuration

Aptio Setup Utility - Copyright (C) 2012 American Megatrends, Inc.
Advanced

Link Speed Wake On LAN	[Auto Neg] [Enabled]	Specifies the port speed used for the selected boot protocol.
		←: Select Screen ↑: Select Item Enter: Select +/-: Change Opt. F1: General Help F2: Previous Values F3: Optimized Defaults F4: Save & Exit ESC: Exit

Version 2.15.1236. Copyright (C) 2012 American Megatrends, Inc.

- ✓ **Link Speed**
Options: Auto Negotiated / 10Mbps Half / 10Mbps full / 100Mbps Half / 100Mbps Full
- ✓ **Wake On LAN**
Options: Enabled / Disabled

5.3.14 Intel(R) I210 Gigabit Network Connection

Aptio Setup Utility - Copyright (C) 2012 American Megatrends, Inc.
Advanced

<pre> PORT CONFIGURATION MENU ▶ NIC Configuration Blink LEDs 0 PORT CONFIGURATION INFORMATION UEFI Driver: Intel(R) PRO/1000 5.7.06 Adapter PBA: FFFFFFF-0FF Chip Type Intel i210 PCI Device ID 153A Bus:Device:Function 00:19:00 Link Status [Disconnected] MAC Address 88:88:88:88:87:88 </pre>	<p>Configure Boot Protocol, Wake on LAN, Link Speed, and VLAN</p> <hr/> <pre> ←: Select Screen ↑↓: Select Item Enter: Select +/-: Change Opt. F1: General Help F2: Previous Values F3: Optimized Defaults F4: Save & Exit ESC: Exit </pre>
---	--

Version 2.15.1236. Copyright (C) 2012 American Megatrends, Inc.

- ✓ **NIC Configuration**
Sub menu: see "NIC Configuration" (page 70)
- ✓ **Blink LEDs**
Options: none
- ✓ **UEFI Driver:**
Options: none
- ✓ **Adapter PBA:**
Options: none
- ✓ **Chip Type**
Options: none
- ✓ **PCI Device ID**
Options: none
- ✓ **PCI Bus:Device:Function**
Options: none
- ✓ **Link Status**
Options: none
- ✓ **Factory MAC Address**
Options: none

5.3.14.1 NIC Configuration

Aptio Setup Utility - Copyright (C) 2012 American Megatrends, Inc.
Advanced

Link Speed Wake On LAN	[Auto Neg] [Enabled]	Specifies the port speed used for the selected boot protocol.
		←: Select Screen ↑: Select Item Enter: Select +/-: Change Opt. F1: General Help F2: Previous Values F3: Optimized Defaults F4: Save & Exit ESC: Exit

Version 2.15.1236. Copyright (C) 2012 American Megatrends, Inc.

- ✓ **Link Speed**
Options: Auto Negotiated / 10Mbps Half / 10Mbps full / 100Mbps Half / 100Mbps Full
- ✓ **Wake On LAN**
Options: Enabled / Disabled

5.3.15 Driver Health

Aptio Setup Utility - Copyright (C) 2012 American Megatrends, Inc.
Advanced

<p>▶ Intel(R) PRO/1000 5.7.06 PCI-E Healthy</p>	<p>Provides Health Status for the Drivers/Controllers</p> <hr/> <p>→: Select Screen ↑↓: Select Item Enter: Select +/-: Change Opt. F1: General Help F2: Previous Values F3: Optimized Defaults F4: Save & Exit ESC: Exit</p>
--	--

Version 2.15.1236. Copyright (C) 2012 American Megatrends, Inc.

- ✓ **Intel(R) PRO/1000 5.7.06 PCI-E**
Sub menu: see "Intel(R) Pro/1000 5.7.06 PCI-E" (page 74)

5.3.15.1 Intel(R) Pro/1000 5.7.06 PCI-E

Aptio Setup Utility - Copyright (C) 2012 American Megatrends, Inc.
Advanced

Controller d2a62b98 Child 0 Healthy	Provides Health Status for the Drivers/Controllers ←: Select Screen ↑↓: Select Item Enter: Select +/-: Change Opt. F1: General Help F2: Previous Values F3: Optimized Defaults F4: Save & Exit ESC: Exit
--	---

Version 2.15.1236. Copyright (C) 2012 American Megatrends, Inc.

- ✓ **Controller x Child n**
Options: none

5.4 Chipset

Aptio Setup Utility - Copyright (C) 2012 American Megatrends, Inc.
Main Advanced CHIPSET Boot Security Save & Exit

<ul style="list-style-type: none">▶ PCH-IO Configuration▶ System Agent (SA) Configuration	<p>PCH Parameters</p> <hr/> <p>←→: Select Screen ↑↓: Select Item Enter: Select +/-: Change Opt. F1: General Help F2: Previous Values F3: Optimized Defaults F4: Save & Exit ESC: Exit</p>
--	---

Version 2.15.1236. Copyright (C) 2012 American Megatrends, Inc.

- ✓ **PCH-IO Configuration**
Sub menu: see "PCH-IO Configuration" (page 76)
- ✓ **System Agent (SA) Configuration**
Sub menu: see "System Agent (SA) Configuration" (page 83)

5.4.1 PCH-IO Configuration

Aptio Setup Utility - Copyright (C) 2012 American Megatrends, Inc.
Chipset

Intel PCH RC Version	1.6.2.0	PCI Express Configuration settings
Intel PCH SKU Name	Q87	
Intel PCH Rev ID	04/C1	
▶ PCI Express Configuration		
▶ USB Configuration		
▶ PCH Azalia Configuration		
PCH LAN Controller	[Enabled]	
Wake on LAN	[Disabled]	
SLP_LAN# Low on DC Power	[Enabled]	
Second LAN Controller	[Enabled]	
CLKRUN# Logic	[Disabled]	
SB CRID	[Disabled]	
SLP_S4 Assertion Width	[Disabled]	
Restore AC Power Loss	[Power On]	
		←: Select Screen ↑: Select Item Enter: Select +/-: Change Opt. F1: General Help F2: Previous Values F3: Optimized Defaults F4: Save & Exit ESC: Exit

Version 2.15.1236. Copyright (C) 2012 American Megatrends, Inc.

- ✓ **Intel PCH RC Version**
Options: none
- ✓ **Intel PCH SKU Name**
Options: none
- ✓ **Intel PCH Rev ID**
Options: none
- ✓ **PCI Express Configuration**
Sub menu: see "PCI Express Configuration" (page 78)
- ✓ **USB Configuration**
Sub menu: see "USB Configuration" (page 81)
- ✓ **PCH Azalia Configuration**
Sub menu: see "PCH Azalia Configuration" (page 82)
- ✓ **PCH LAN Controller**
Options: Disabled / Enabled
- ✓ **Wake on LAN**
Options: Disabled / Enabled
- ✓ **SLP_LAN# Low on DC Power**
Options: Disabled / Enabled
- ✓ **Second LAN Controller**
Options: Disabled / Enabled
- ✓ **CLKRUN# Logic**
Options: Disabled

- ✓ **SB CRID**
Options: Disabled / Enabled

- ✓ **SLP_S4 Assertion Width**
Options: Disabled / 1-2 Seconds / 2-3 Seconds / 3-4 Seconds / 4-5 Seconds

- ✓ **Restore AC Power Loss**
Options: Power Off / Power On / Last State

5.4.1.1 PCI Express Configuration

Aptio Setup Utility - Copyright (C) 2012 American Megatrends, Inc.
Chipset

<pre> PCI Express Configuration PCI Express Clock Gating [Enabled] DMI Link ASPM Control [Enabled] DMI Link Extended Synch Control [Disabled] PCIe-USB Glitch W/A [Disabled] Subtractive Decode [Disabled] PCI Express Root Port 1 PCI Express Root Port 2 is assigned to PCIe to PCI Bridge PCI Express Root Port 3 is assigned to LAN PCI Express Root Port 4 is assigned to LAN2 ▶ PCI Express Root Port 5 ▶ PCI Express Root Port 6 ▶ PCI Express Root Port 7 ▶ PCI Express Root Port 8 </pre>	<pre> Enable or disable PCI Express Clock Gating for each root port. ----- ←: Select Screen ↑: Select Item Enter: Select +/-: Change Opt. F1: General Help F2: Previous Values F3: Optimized Defaults F4: Save & Exit ESC: Exit </pre>
--	--

Version 2.15.1236. Copyright (C) 2012 American Megatrends, Inc.

- ✓ **PCI Express Clock Gating**
Options: Disabled / Enabled
- ✓ **DMI Link ASPM Control**
Options: Disabled / Enabled
- ✓ **DMI Link Extended Synch Control**
Options: Disabled / Enabled
- ✓ **PCIe-USB Glitch W/A**
Options: Disabled / Enabled
- ✓ **Subtractive Decode**
Options: Disabled
- ✓ **PCI Express Root Port X**
Sub menu: see "PCI Express Root Port" (page 79)

5.4.1.1.1 PCI Express Root Port

Aptio Setup Utility - Copyright (C) 2012 American Megatrends, Inc.
Chipset

PCI Express Root Port 2	[Enabled]	▲ Control the PCI Express Root Port.
ASPM Support	[Auto]	
L1 Substates	[L1.1 & L1.2]	
URR	[Disabled]	
FER	[Disabled]	
NFER	[Disabled]	
CER	[Disabled]	
CTO	[Disabled]	
SEFE	[Disabled]	
SENF	[Disabled]	
SECE	[Disabled]	
PME SCI	[Enabled]	
Hot Plug	[Disabled]	
PCIe Speed	[Auto]	
Detect Non-Compliance Device	[Disabled]	
Extra Bus Reserved	0	
Reserved Memory	10	
Prefetchable Memory	10	
Reserved I/O	4	
PCIe LTR	[Enabled]	
PCIe LTR Lock	[Enabled]	
Snoop Latency Override	[Manual]	
Snoop Latency Multiplier	[1024 ns]	
Snoop Latency Value	60	
Non Snoop Latency Override	[Manual]	
		▼
		←: Select Screen
		↑: Select Item
		Enter: Select
		+/-: Change Opt.
		F1: General Help
		F2: Previous Values
		F3: Optimized Defaults
		F4: Save & Exit
		ESC: Exit

Version 2.15.1236. Copyright (C) 2012 American Megatrends, Inc.

- ✓ **PCI Express Root Port x**
Options: Disabled / Enabled
- ✓ **ASPM Support**
Options: Disabled / L0s / L1 / L0sL1 / Auto
- ✓ **L1 Substates**
Options: Disabled / L1.1 / L1.2 / L1.1 & L1.2
- ✓ **URR**
Options: Disabled / Enabled
- ✓ **FER**
Options: Disabled / Enabled
- ✓ **NFER**
Options: Disabled / Enabled
- ✓ **CER**
Options: Disabled / Enabled
- ✓ **CTO**
Options: Disabled / Enabled
- ✓ **SEFE**
Options: Disabled / Enabled
- ✓ **SENF**
Options: Disabled / Enabled
- ✓ **SECE**
Options: Disabled / Enabled

-
- ✓ **PME SCI**
Options: Disabled / Enabled
 - ✓ **Hot Plug**
Options: Disabled / Enabled
 - ✓ **PCIe Speed**
Options: Auto / Gen1 / Gen2
 - ✓ **Detect Non-Compliance Device**
Options: Disabled / Enabled
 - ✓ **Extra Bus Reserved**
Options: 0...7
 - ✓ **Reserved Memory**
Options: 1...20
 - ✓ **Prefetchable Memory**
Options: 1...20
 - ✓ **Reserved I/O**
Options: 4 / 8 / 12 / 16 / 20
 - ✓ **PCIE LTR**
Options: Disabled / Enabled
 - ✓ **PCIE LTR Lock**
Options: Disabled / Enabled
 - ✓ **Snoop Latency Override**
Options: Disabled / Manual / Auto
 - ✓ **Snoop Latency Multiplier**
Options: 1 / 32 / 1024 / 32768 / 1048576 / 33554432 ns
 - ✓ **Snoop Latency Value**
Options: none
 - ✓ **Non Snoop Latency Override**
Options: Disabled / Manual / Auto
 - ✓ **Non Snoop Latency Multiplier**
Options: 1 / 32 / 1024 / 32768 / 1048576 / 33554432 ns
 - ✓ **Non Snoop Latency Value**
Options: none

5.4.1.2 USB Configuration

Aptio Setup Utility - Copyright (C) 2012 American Megatrends, Inc.
Chipset

USB Configuration		Precondition work on USB host controller and root ports for faster enumeration.
USB Precondition	[Disabled]	
XHCI Mode	[Manual]	
BTCG	[Enabled]	
XHCI Pre-Boot Driver		
	[Enabled]	
Route USB 2.0 pins to which HC?		
	[Route Per-Pin]	
USB 2.0 PIN #0	[Route to EHCI]	
USB 2.0 PIN #1	[Route to EHCI]	
USB 2.0 PIN #2	[Route to EHCI]	
USB 2.0 PIN #3	[Route to EHCI]	
USB 2.0 PIN #4	[Route to EHCI]	
USB 2.0 PIN #5	[Route to EHCI]	
USB 2.0 PIN #6	[Route to EHCI]	
USB 2.0 PIN #7	[Route to EHCI]	
USB 2.0 PIN #8	[Route to EHCI]	
USB 2.0 PIN #9	[Route to EHCI]	
USB 2.0 PIN #10	[Route to EHCI]	
USB 2.0 PIN #11	[Route to EHCI]	
USB 2.0 PIN #12	[Route to EHCI]	
USB 2.0 PIN #13	[Route to EHCI]	
Enable USB 3.0 pins		
	[Select Per-Pin]	

←: Select Screen
↑: Select Item
Enter: Select
+/-: Change Opt.
F1: General Help
F2: Previous Values
F3: Optimized Defaults
F4: Save & Exit
ESC: Exit

Version 2.15.1236. Copyright (C) 2012 American Megatrends, Inc.

- ✓ **USB Precondition**
Options: Disabled / Enabled
- ✓ **XHCI Mode**
Options: Smart Auto / Auto / Enabled / Disabled / Manual
- ✓ **BTCG**
Options: Disabled / Enabled
- ✓ **XHCI Pre-Boot Driver**
Options: Disabled / Enabled
- ✓ **Route USB 2.0 pins to which HC?**
Options: Route Per-Pin / Route all Pins to EHCI / Route all Pins to XHCI
- ✓ **USB 2.0 PIN #X**
Options: Route to EHCI / Route to XHCI
- ✓ **Enable USB 3.0 pins**
Options: Select Per-Pin / Disable all Pins / Enable all Pins
- ✓ **USB 3.0 PIN #X**
Options: Disabled / Enabled
- ✓ **USB Ports Per-Port Disable Control**
Options: Disabled / Enabled
- ✓ **USB Port #X**
Options: Disabled / Enabled
- ✓ **USB3.0 Port #X**
Options: Disabled / Enabled

5.4.1.3 PCH Azalia Configuration

Aptio Setup Utility - Copyright (C) 2012 American Megatrends, Inc.
Chipset

<p>PCH Azalia Configuration</p> <p>Azalia [Enabled]</p> <p>Azalia PME [Disabled]</p>	<p>Control Detection of the Azalia device. Disabled = Azalia will be unconditionally disabled Enabled = Azalia will be unconditionally Enabled Auto = Azalia will be enabled if present, disabled otherwise.</p> <hr/> <p>←: Select Screen ↑: Select Item Enter: Select +/-: Change Opt. F1: General Help F2: Previous Values F3: Optimized Defaults F4: Save & Exit ESC: Exit</p>
--	---

Version 2.15.1236. Copyright (C) 2012 American Megatrends, Inc.

- ✓ **Azalia**
Options: Disabled / Enabled / Auto
- ✓ **Azalia PME**
Options: Disabled / Enabled

5.4.2 System Agent (SA) Configuration

Aptio Setup Utility - Copyright (C) 2012 American Megatrends, Inc.
Chipset

System Agent Bridge Name	Haswell	Check to enable VT-d function on MCH.
System Agent RC Version	1.6.2.0	
VT-d Capability	Supported	
VT-d	[Enabled]	
CHAP Device (B0:D7:F0)	[Disabled]	
Thermal Device (B0:D4:F0)	[Disabled]	
CPU SA Audio Device (B0:D3:F0)	[Disabled]	
Enable NB CRID	[Disabled]	
BDAT ACPI Table Support	[Disabled]	
▶ Graphics Configuration		
▶ NB PCIe Configuration		
		←: Select Screen ↑↓: Select Item Enter: Select +/-: Change Opt. F1: General Help F2: Previous Values F3: Optimized Defaults F4: Save & Exit ESC: Exit

Version 2.15.1236. Copyright (C) 2012 American Megatrends, Inc.

- ✓ **CHAP Device (B0:D7:F0)**
Options: Disabled / Enabled
- ✓ **Thermal Device (B0:D4:F0)**
Options: Disabled / Enabled
- ✓ **CPU SA Audio Device (B0:D3:F0)**
Options: Disabled / Enabled
- ✓ **Enable NB CRID**
Options: Disabled / Enabled
- ✓ **BDAT ACPI Table Support**
Options: Disabled / Enabled
- ✓ **Graphics Configuration**
Sub menu: see "Graphics Configuration" (page 84)
- ✓ **NB PCIe Configuration**
Sub menu: see "NB PCIe Configuration" (page 87)

5.4.2.1 Graphics Configuration

Aptio Setup Utility - Copyright (C) 2012 American Megatrends, Inc.
Chipset

Graphics Configuration		Graphics turbo IMON current values supported (14-31)
IGFX VBIOS Version	2189	
IGFX Frequency	800 MHz	
Graphics Turbo IMON Current	31	
Primary Display	[Auto]	
Primary PEG	[Auto]	
Primary PCIE	[Auto]	
Internal Graphics	[Auto]	
Aperture Size	[256MB]	
DVMT Pre-Allocated	[64M]	
DVMT Total Gfx Mem	[256M]	
Gfx Low Power Mode	[Disabled]	
Panel Power Enable	[Disabled]	
▶ LCD Control		
		←: Select Screen ↑: Select Item Enter: Select +/-: Change Opt. F1: General Help F2: Previous Values F3: Optimized Defaults F4: Save & Exit ESC: Exit

Version 2.15.1236. Copyright (C) 2012 American Megatrends, Inc.

- ✓ **IGFX VBIOS Version**
Options: none
- ✓ **IGFX Frequency**
Options: none
- ✓ **Graphics Turbo IMON Current**
Options: 14...31
- ✓ **Primary Display**
Options: Auto / IGFX / PEG / PCI
- ✓ **Primary PEG**
Options: Auto / PEG11 / PEG 12
- ✓ **Primary PCIE**
Options: Auto / PCIE1 / PCIE2 / ... / PCIE7
- ✓ **Internal Graphics**
Options: Auto / Disabled / Enabled
- ✓ **Aperture Size**
Options: 128MB / 256MB / 512MB
- ✓ **DVMT Pre-Allocated**
Options: 32M / 64M ... 480M / 512M / 1024M
- ✓ **DVMT Total Gfx Mem**
Options: 128M / 256M / MAX
- ✓ **Gfx Low Power Mode**
Options: Disabled / Enabled

- ✓ **Panel Power Enable**
Options: Disabled / Enabled

- ✓ **LCD Control**
Sub menu: see "LCD Control" (page 86)

5.4.2.1.1 LCD Control

Aptio Setup Utility - Copyright (C) 2012 American Megatrends, Inc.
Chipset

LCD Control		Select the Video Device which will be activated during POST. This has no effect if external graphics present. Secondary boot display selection will appear based on your selection. VGA modes will be supported only on primary display
Primary IGFX Boot Display	[CRT]	
Secondary IGFX Boot Display	[Disabled]	
SDVO-LFP Panel Type	[VBIOS Default]	
BIA	[Auto]	
Spread Spectrum clock Chip	[Off]	
ALS Support	[Disabled]	
		←: Select Screen ↑↓: Select Item Enter: Select +/-: Change Opt. F1: General Help F2: Previous Values F3: Optimized Defaults F4: Save & Exit ESC: Exit

Version 2.15.1236. Copyright (C) 2012 American Megatrends, Inc.

- ✓ **Primary IGFX Boot Display**
Options: VBIOS Default / CRT / EFP / LFP / EFP3 / EFP2 / LFP2
- ✓ **Secondary IGFX Boot Display**
Options: VBIOS Default / CRT / EFP / LFP / EFP3 / EFP2 / LFP2
- ✓ **SDVO-LFP Panel Type**
Options: VBIOS Default / 1024x768 SDVO-LFP / 1280x1024 SDVO-LFP / 1400x1050 SDVO-LFP / 1600x1200 SDVO-LFP
- ✓ **BIA**
Options: Auto / Disabled / Level 1..5
- ✓ **Spread Spectrum Clock Chip**
Options: Off / Hardware / Software
- ✓ **ALS Support**
Options: Disabled / Enabled

5.4.2.2 NB PCIe Configuration

Aptio Setup Utility - Copyright (C) 2012 American Megatrends, Inc.
Chipset

NB PCIe Configuration		▲	Configure PEG0 B0:D1:F0 Gen1-Gen3
PEG0	Not present	█	
PEG0 - Gen X	[Auto]	█	
PEG1	Not Present	█	
PEG1 - Gen X	[Auto]	█	
PEG2	Not Present	█	
PEG2 - Gen X	[Auto]	█	
Run-time C7 Allowed	[Enabled]	█	
Enable PEG	[Auto]	█	
Detect Non-Compliance Device	[Disabled]	█	
Program PCIe ASPM after OpROM	[Disabled]	█	
PEG0 De-emphasis Control	[-3.5 dB]	█	
PEG1 De-emphasis Control	[-3.5 dB]	█	
PEG2 De-emphasis Control	[-3.5 dB]	█	
PEG0 - ASPM	[ASPM L0s]	█	←: Select Screen
ASPM L0s	[Both Root and Endpo...]	█	↑: Select Item
PEG1 - ASPM	[ASPM L0sL1]	█	Enter: Select
ASPM L0s	[Both Root and Endpo...]	█	+/-: Change Opt.
PEG2 - ASPM	[ASPM L0sL1]	█	F1: General Help
ASPM L0s	[Both Root and Endpo...]	█	F2: Previous Values
PEG Sampler Calibrate	[Disabled]	█	F3: Optimized Defaults
Swing Control	[Full]	█	F4: Save & Exit
PEG Gen3 Equalization	[Disabled]	█	ESC: Exit
Gen3 Eq Preset Search	[Enabled]	▼	

Version 2.15.1236. Copyright (C) 2012 American Megatrends, Inc.

- ✓ **PEGn - Gen X**
Options: Auto / Gen1 / Gen2 / Gen3
- ✓ **Run-time C7 Allowed**
Options: Disabled / Enabled
- ✓ **Enable PEG**
Options: Disabled / Enabled / Auto
- ✓ **Detect Non-Compliance Device**
Options: Disabled / Enabled
- ✓ **Program PCIe ASPM after OpROM**
Options: Enabled / Disabled
- ✓ **De-emphasis Control**
Options: -6 dB / -3.5 dB
- ✓ **PEGn ASPM**
Options: Disabled / Auto / ASPM L0s / ASPM L1 / ASPM L0sL1
- ✓ **ASPM L0s**
Options: Root Port Only / Endpoint Port Only / Both Root and Endpoint Ports
- ✓ **PEG Sampler Calibrate**
Options: Auto / Disabled / Enabled
- ✓ **Swing Control**
Options: Reduced / Half / Full
- ✓ **Gen3 Equalization**
Options: Disabled / Enabled

-
- ✓ **Gen3 Eq Preset Search**
Options: Enabled / Disabled

 - ✓ **Always re-search Gen3 Eq Preset**
Options: Enabled / Disabled

 - ✓ **Allow PERST# GPIO Usage**
Options: Enabled / Disabled

 - ✓ **Preset Search Dwell Time**
Options: 0-65535

 - ✓ **Timing Margin Steps**
Options: 1-255

 - ✓ **Timing Start Margin**
Options: 4-255

 - ✓ **Voltage Margin Steps**
Options: 1-255

 - ✓ **Voltage Start Margin**
Options: 4-255

 - ✓ **Favor Timing Margin**
Options: Enabled / Disabled

 - ✓ **Error Target**
Options: 0-65535

 - ✓ **PEG RxCEM LoopBack Mode**
Options: Enabled / Disabled

 - ✓ **PEG Lane number for Test**
Options: 0-15

 - ✓ **PCIe Gen3 RxCTLEp Setting**
Options: 0...15

5.4.2.2.1 PEG Gen3 Root Port Preset Value for each Lane

Aptio Setup Utility - Copyright (C) 2012 American Megatrends, Inc.
Chipset

PEG Gen3 Root Port Preset Value for each Lane	Lane 0 Root port preset value for Gen3 Equalization.
Gen3 Root Port Preset Lane 0 8	
Gen3 Root Port Preset Lane 1 8	
Gen3 Root Port Preset Lane 2 8	
Gen3 Root Port Preset Lane 3 8	
Gen3 Root Port Preset Lane 4 8	
Gen3 Root Port Preset Lane 5 8	
Gen3 Root Port Preset Lane 6 8	
Gen3 Root Port Preset Lane 7 8	
Gen3 Root Port Preset Lane 8 8	
Gen3 Root Port Preset Lane 9 8	
Gen3 Root Port Preset Lane 10 8	
Gen3 Root Port Preset Lane 11 8	
Gen3 Root Port Preset Lane 12 8	
Gen3 Root Port Preset Lane 13 8	
Gen3 Root Port Preset Lane 14 8	
Gen3 Root Port Preset Lane 15 8	
	←: Select Screen ↑: Select Item Enter: Select +/-: Change Opt. F1: General Help F2: Previous Values F3: Optimized Defaults F4: Save & Exit ESC: Exit

Version 2.15.1236. Copyright (C) 2012 American Megatrends, Inc.

- ✓ **Gen3 Root Port Preset Value for each Lane**
Options: 1..11

5.4.2.2.3 PEG Gen3 Endpoint Hint Value each Lane

Aptio Setup Utility - Copyright (C) 2012 American Megatrends, Inc.
Chipset

PEG Gen3 Endpoint Hint Value each Lane	Lane 0 End Point Hint value for Gen3 Equalization.
Gen3 Root Port Preset Lane 0	2
Gen3 Root Port Preset Lane 1	2
Gen3 Root Port Preset Lane 2	2
Gen3 Root Port Preset Lane 3	2
Gen3 Root Port Preset Lane 4	2
Gen3 Root Port Preset Lane 5	2
Gen3 Root Port Preset Lane 6	2
Gen3 Root Port Preset Lane 7	2
Gen3 Root Port Preset Lane 8	2
Gen3 Root Port Preset Lane 9	2
Gen3 Root Port Preset Lane 10	2
Gen3 Root Port Preset Lane 11	2
Gen3 Root Port Preset Lane 12	2
Gen3 Root Port Preset Lane 13	2
Gen3 Root Port Preset Lane 14	2
Gen3 Root Port Preset Lane 15	2

Version 2.15.1236. Copyright (C) 2012 American Megatrends, Inc.

- ✓ **PEG Gen3 Endpoint Hint Value each Lane**
Options: 0..11

5.4.2.2.4 PCIe Gen3 RxCTLEp Setting

Aptio Setup Utility - Copyright (C) 2012 American Megatrends, Inc.
Chipset

PCIe Gen3 RxCTLEp Setting		Select the Video Device which will be activated during POST. This has no effect if external graphics present. Secondary boot display selection will appear based on your selection. VGA modes will be supported only on primary display
PCIe Gen3 RxCTLEp Setting 0	8	
PCIe Gen3 RxCTLEp Setting 1	8	
PCIe Gen3 RxCTLEp Setting 2	8	
PCIe Gen3 RxCTLEp Setting 3	8	
PCIe Gen3 RxCTLEp Setting 4	8	
PCIe Gen3 RxCTLEp Setting 5	8	
PCIe Gen3 RxCTLEp Setting 6	8	
PCIe Gen3 RxCTLEp Setting 7	8	
		←: Select Screen ↑↓: Select Item Enter: Select +/-: Change Opt. F1: General Help F2: Previous Values F3: Optimized Defaults F4: Save & Exit ESC: Exit

Version 2.15.1236. Copyright (C) 2012 American Megatrends, Inc.

- ✓ **PCIe Gen3 RxCTLEp Setting x**
Options: 0..15

5.5 Boot

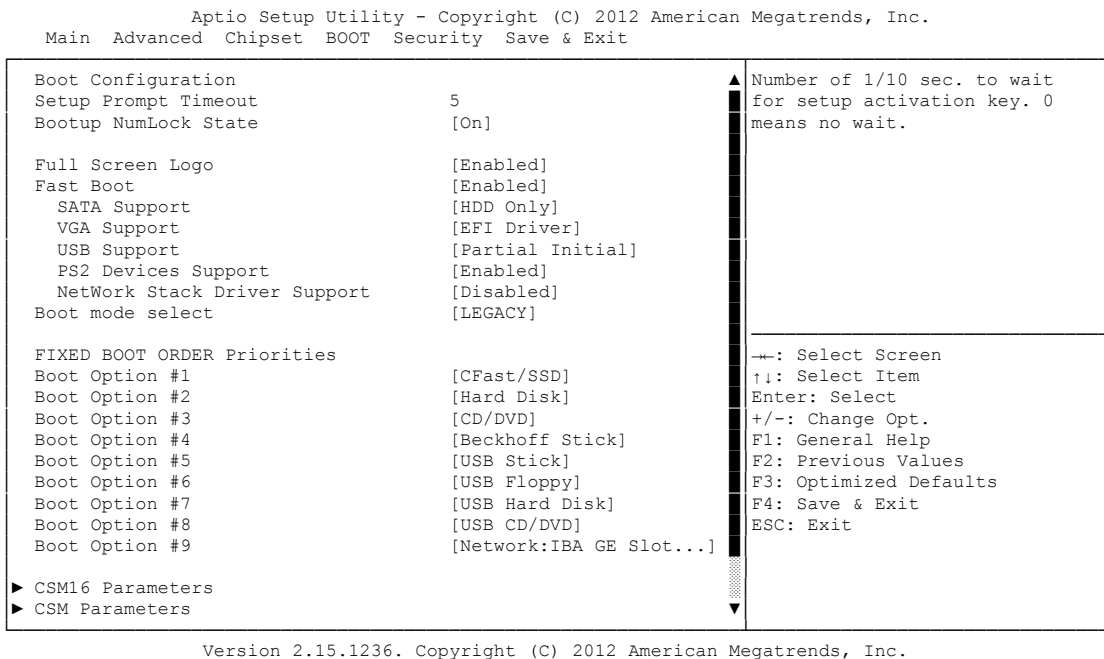

- ✓ **Setup Prompt Timeout**
Options: 0...65535 [x 1/10 sec.]
- ✓ **Bootup NumLock State**
Options: On / Off
- ✓ **Full Screen Logo**
Options: Disabled / Enabled
- ✓ **Fast Boot**
Options: Disabled / Enabled
- ✓ **SATA Support**
Options: Last Boot HDD Only / All Sata Devices / HDD Only
- ✓ **VGA Support**
Options: Auto / EFI Driver
- ✓ **USB Support**
Options: Disabled / Full Initial / Partial Initial
- ✓ **PS2 Devices Support**
Options: Disabled / Enabled
- ✓ **NetWork Stack Driver Support**
Options: Disabled / Enabled
- ✓ **Boot mode select**
Options: Legacy / UEFI / DUAL
- ✓ **Fixed Boot Order Priorities**
Options: Review or change the sequence of available boot devices

-
- ✓ **CSM16 Parameters**
Sub menu: see "CSM16 Parameters" (page 95)

 - ✓ **CSM Parameters**
Sub menu: see "CSM Parameters" (page 96)

5.5.1 CSM16 Parameters

Aptio Setup Utility - Copyright (C) 2012 American Megatrends, Inc.
 Boot

CSM16 Parameters		UPON REQUEST - GA20 can be disabled using BIOS services. ALWAYS - do not allow disabling GA20; this option is useful when any RT code is executed above 1MB.
CSM16 Module Version	07.71	
GateA20 Active	[Upon Request]	
Option ROM Messages	[Force BIOS]	
INT19 Trap Response	[Immediate]	
		←: Select Screen ↑↓: Select Item Enter: Select +/-: Change Opt. F1: General Help F2: Previous Values F3: Optimized Defaults F4: Save & Exit ESC: Exit

Version 2.15.1236. Copyright (C) 2012 American Megatrends, Inc.

- ✓ **GateA20 Active**
Options: Upon Request / Always
- ✓ **Option ROM Messages**
Options: Force BIOS / Keep Current
- ✓ **INT9 Trap Response**
Options: Immediate / Postponed

5.5.2 CSM Parameters

Aptio Setup Utility - Copyright (C) 2012 American Megatrends, Inc.
Main Advanced Chipset BOOT Security Save & Exit

Launch CSM	[Enabled]	This option controls if CSM will be launched
Boot option filter	[UEFI and Legacy]	
Launch PXE OpROM policy	[Legacy only]	
Launch Storage OpROM policy	[Legacy only]	
Launch Video OpROM policy	[Legacy only]	
Other PCI device ROM priority	[UEFI OpROM]	
		←: Select Screen ↑↓: Select Item Enter: Select +/-: Change Opt. F1: General Help F2: Previous Values F3: Optimized Defaults F4: Save & Exit ESC: Exit

Version 2.15.1236. Copyright (C) 2012 American Megatrends, Inc.

- ✓ **Launch CSM**
Options: Enabled / Disabled
- ✓ **Boot option filter**
Options: UEFI and Legacy / Legacy only / UEFI only
- ✓ **Launch PXE OpROM policy**
Options: Disable / Enable
- ✓ **Launch Storage OpROM policy**
Options: Do not launch / UEFI only / Legacy only
- ✓ **Launch Video OpROM policy**
Options: Do not launch / UEFI only / Legacy only
- ✓ **Other PCI device ROM priority**
Options: UEFI OpROM / Legacy OpROM

5.6.1 Secure Boot Menu

Aptio Setup Utility - Copyright (C) 2012 American Megatrends, Inc.
Security

System Mode	Setup	Secure Boot can be enabled if 1.System running in User mode with enrolled Platform Key(PK) 2.CSM function is disabled
Secure Boot	Not Active	
Secure Boot Support	[Disabled]	
Secure Boot Mode	[Custom]	
▶ Key Management		
		←: Select Screen ↑↓: Select Item Enter: Select +/-: Change Opt. F1: General Help F2: Previous Values F3: Optimized Defaults F4: Save & Exit ESC: Exit

Version 2.15.1236. Copyright (C) 2012 American Megatrends, Inc.

- ✓ **Secure Boot Support**
Options: Disabled / Enabled
- ✓ **Secure Boot Mode**
Options: Standard / Custom
- ✓ **Key Management**
Sub menu: see "Key Management" (page 99)

5.6.1.1 Key Management

Aptio Setup Utility - Copyright (C) 2012 American Megatrends, Inc.
Security

Factory Default Key Provisioning [Disabled] ▶ Enroll All Factory Default Keys ▶ Save All Secure Boot Variables Platform Key (PK) NOT INSTALLED ▶ Delete PK ▶ Set new PK Key Exchange Key Database (KEK) NOT INSTALLED ▶ Delete KEK ▶ Set new KEK ▶ Append KEK Authorized Signature Database (DB) NOT INSTALLED ▶ Delete DB ▶ Set new DB ▶ Append DB Forbidden Signature Database (DBX) NOT INSTALLED ▶ Delete DBX ▶ Set new DBX ▶ Append DBX	Install Factory default Secure Boot Keys when system is in Setup Mode. ←: Select Screen ↑: Select Item Enter: Select +/-: Change Opt. F1: General Help F2: Previous Values F3: Optimized Defaults F4: Save & Exit ESC: Exit
---	--

Version 2.15.1236. Copyright (C) 2012 American Megatrends, Inc.

- ✓ **Factory Default Key Provisioning**
Options: Disabled / Enabled
- ✓ **Enroll All Factory Default Keys**
Options: Press [Enter]
- ✓ **Save All Secure Boot Variables**
Options: Press [Enter]
- ✓ **Delete PK**
Options: Press [Enter]
- ✓ **Set new PK**
Options: Press [Enter]
- ✓ **Delete KEK**
Options: Press [Enter]
- ✓ **Set new KEK**
Options: Press [Enter]
- ✓ **Append KEK**
Options: Press [Enter]
- ✓ **Delete DB**
Options: Press [Enter]
- ✓ **Set new DB**
Options: Press [Enter]
- ✓ **Append DB**
Options: Press [Enter]

- ✓ **Delete DBX**
Options: Press [Enter]
- ✓ **Set new DBX**
Options: Press [Enter]
- ✓ **Append DBX**
Options: Press [Enter]

5.7 Save & Exit

Aptio Setup Utility - Copyright (C) 2012 American Megatrends, Inc.
Main Advanced Chipset Boot Security SAVE & EXIT

<p>Save Changes and Reset Discard Changes and Reset</p> <p>Restore Optimized Defaults Save as User Defaults Restore User Defaults</p> <p>Boot Override IBA GE Slot 00CB v1410</p>	<p>Reset the system after saving the changes.</p> <hr/> <p>←→: Select Screen ↑↓: Select Item Enter: Select +/-: Change Opt. F1: General Help F2: Previous Values F3: Optimized Defaults F4: Save & Exit ESC: Exit</p>
---	---

Version 2.15.1236. Copyright (C) 2012 American Megatrends, Inc.

- ✓ **Save Changes and Reset**
Options: Press [Enter]
- ✓ **Discard Changes and Reset**
Options: Press [Enter]
- ✓ **Restore Defaults**
Options: Press [Enter]
- ✓ **Save as User Defaults**
Options: Press [Enter]
- ✓ **Restore User Defaults**
Options: Press [Enter]
- ✓ **Boot Override**
Options: Press [Enter]
- ✓ **IBA GE Slot 00C8 v1381**
Options: none

5.8 BIOS-Update

If a BIOS update needs to be done, the program "DecdFlash" as well as a bootable medium which contains the newest BIOS version is used for this. It is important, that the program is started from a DOS environment without a virtual memory manager, for example "EMM386.EXE". In case such a memory manager is loaded, the program will stop with an error message.

DecdFlash is a program which provides automatic BIOS updates on any AMI-BIOS boards. All files need to be copied from the .zip-file in another directory.

The system may not be interrupted during the flash process, otherwise the update is stopped and the BIOS is destroyed afterwards.

The program should be started as follows:

```
DecdFlsh BIOS-Filename
```

After checking the name of the BIOS file and its length the BIOS will be programmed.

The flashing takes nearly 75 seconds. The firmware will get updated automatically.



Attention

A faulty BIOS-Update process may cause damages on the board!

Updating the BIOS in an improper way can render the board unusable. Therefore, you should only update the BIOS if you really need the changes/corrections which come with the new BIOS version.

Before you proceed to update the BIOS you need to make absolutely sure that you have the right BIOS file which was issued for the exact board and exact board revision that you wish to update. If you try to update the BIOS using the wrong file the board will not start up again.

6 Mechanical Drawings

 <p>Notice</p>	<p>All dimensions are in mil (1 mil = 0,0254 mm)</p>
--	--

6.1 PCB: Mounting Holes

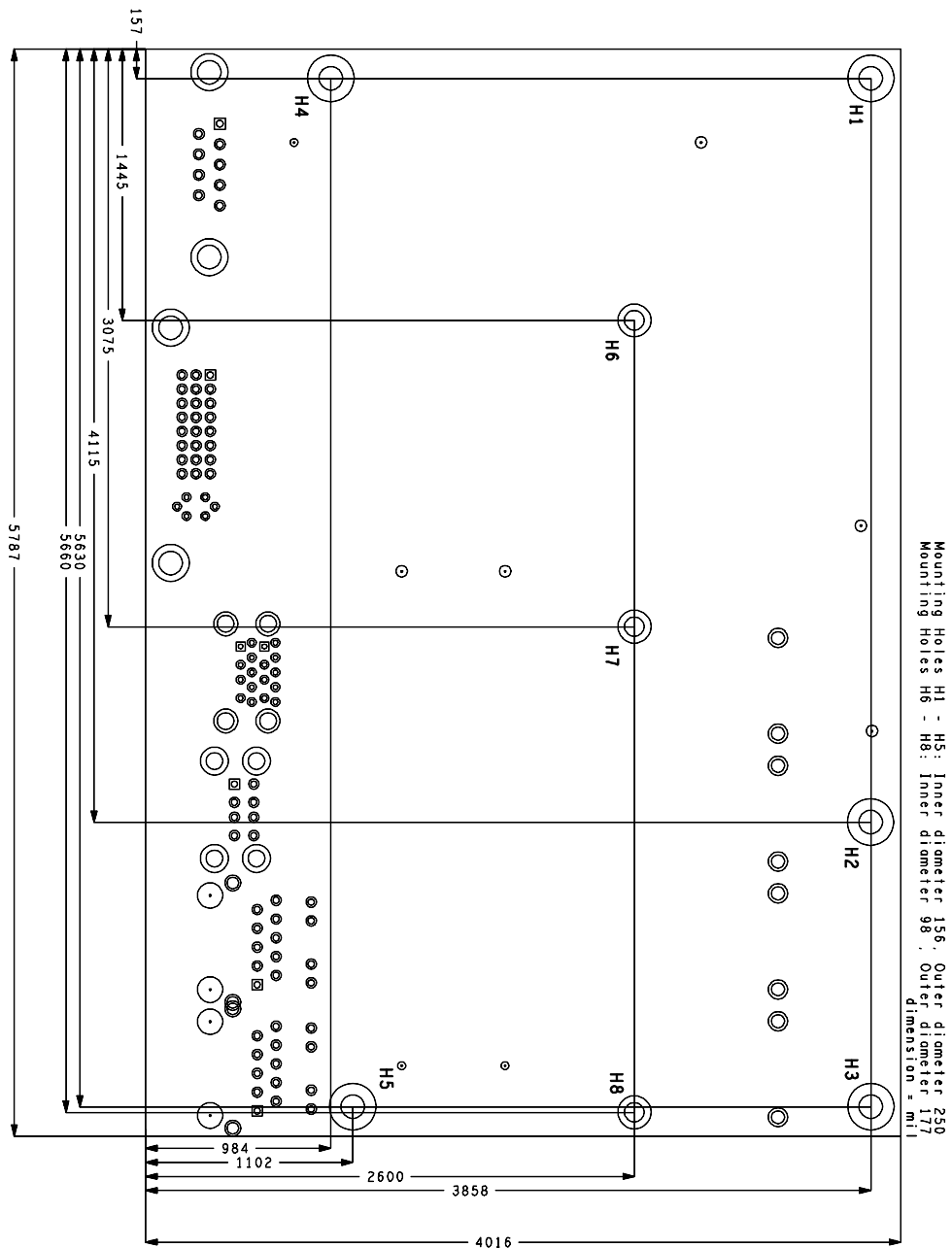

6.2 PCB: Pin 1 Dimensions - Top

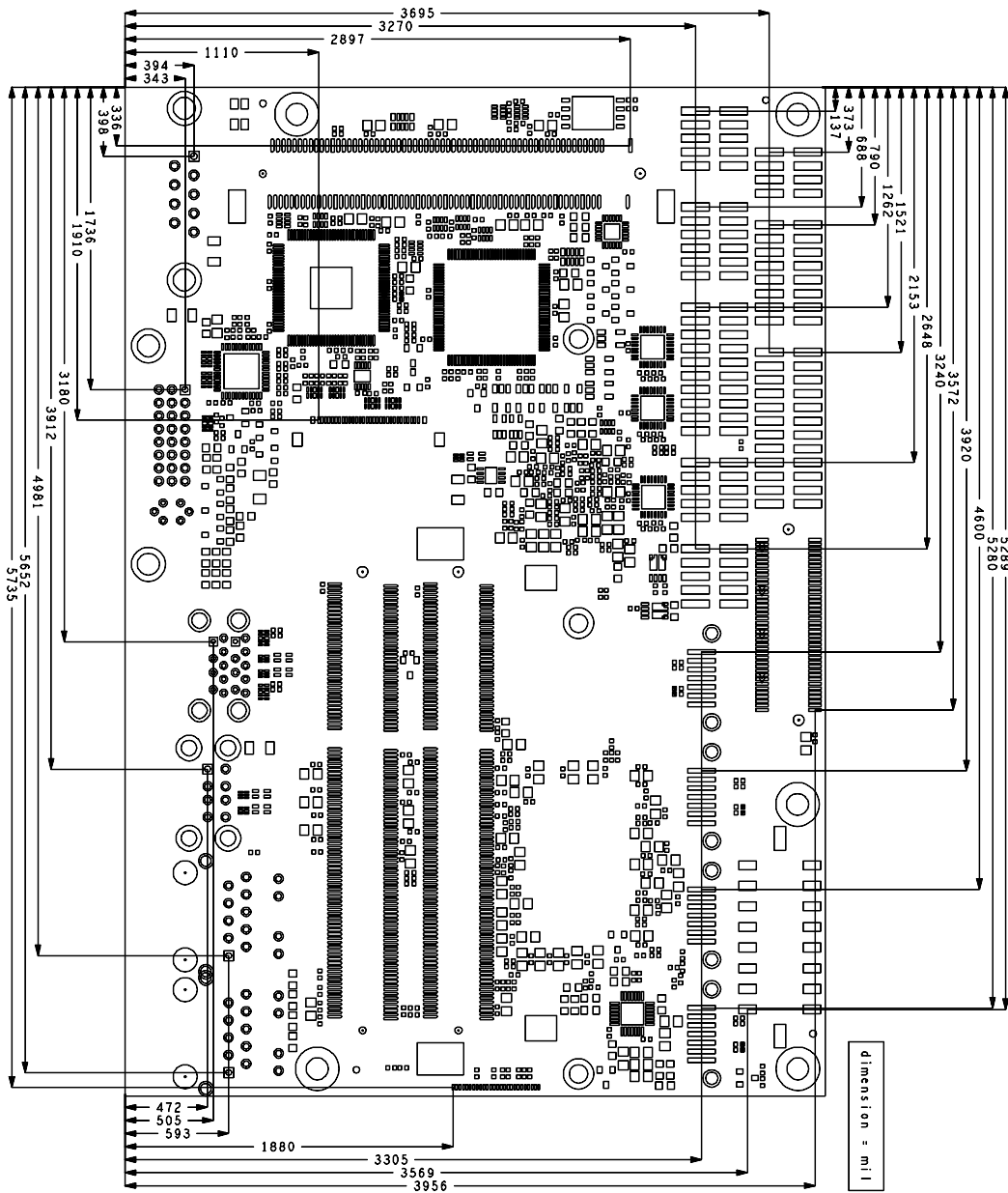

6.3 PCB: Die Center

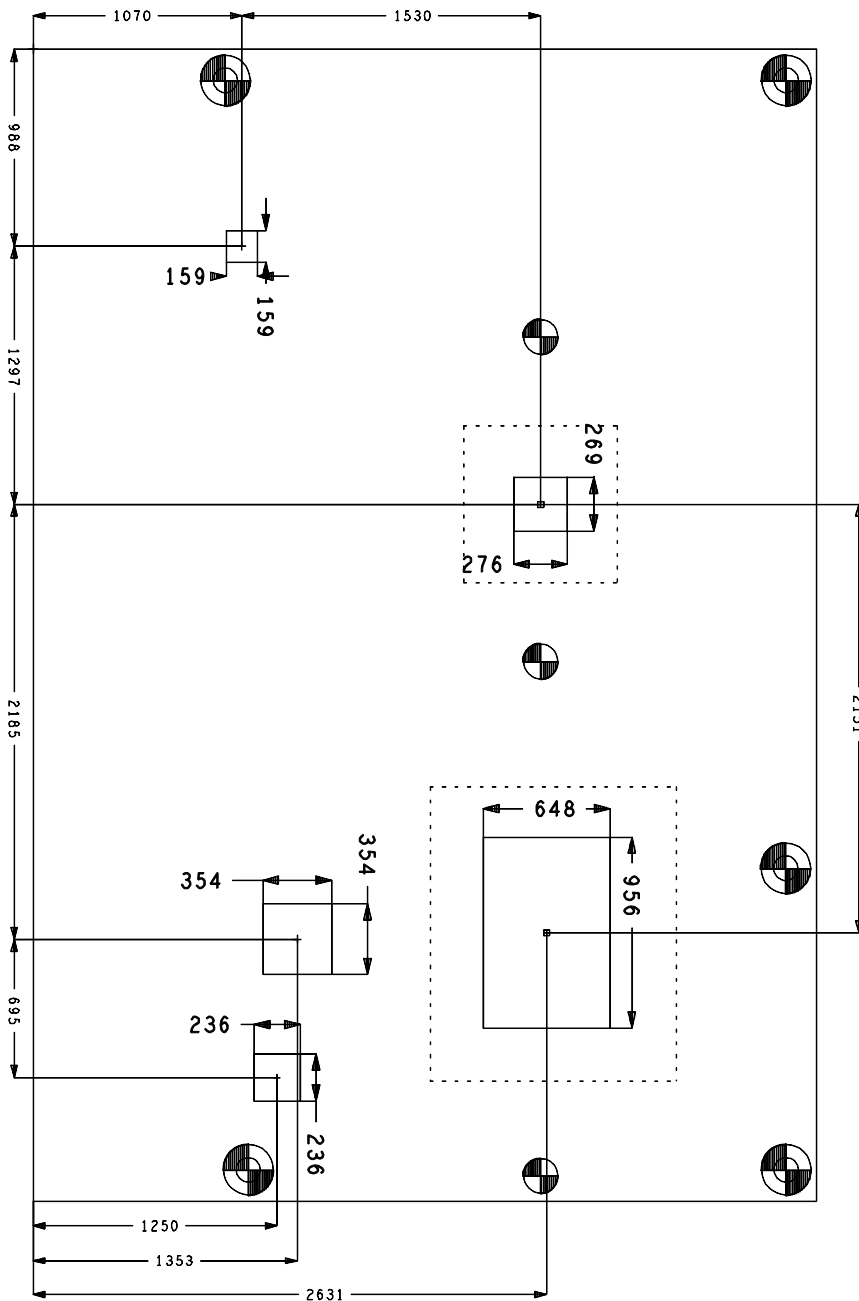

7 Technical Data

7.1 Electrical Data

Power Supply:

Board: 5 Volt +/- 5% (5 Volt Suspend / 12 Volt Fan)
 RTC: >= 3 Volt

Electric Power Consumption:

RTC: <= 10 μ A

7.2 Environmental Conditions

Temperature Range:

Operating: 0°C to +60°C (extended temperature on request)
 Storage: -25°C up to +85°C
 Shipping: -25°C up to +85°C, for packaged boards

Temperature Changes:

Operating: 0.5°C per minute, 7.5°C per 30 minutes
 Storage: 1.0°C per minute
 Shipping: 1.0°C per minute, for packaged boards

Relative Humidity:

Operating: 5% up to 85% (non condensing)
 Storage: 5% up to 95% (non condensing)
 Shipping: 5% up to 100% (non condensing), for packaged boards

Shock:

Operating: 150m/s², 6ms
 Storage: 400m/s², 6ms
 Shipping: 400m/s², 6ms, for packaged boards

Vibration:

Operating: 10 up to 58Hz, 0.075mm amplitude
 58 up to 500Hz, 10m/s²
 Storage: 5 up to 9Hz, 3.5mm amplitude
 9 up to 500Hz, 10m/s²
 Shipping: 5 up to 9Hz, 3.5mm amplitude
 9 up to 500Hz, 10m/s², for packaged boards



Notice

Shock and vibration

Shock and vibration figures pertain to the motherboard alone and do not include additional components such as heat sinks, memory modules, cables etc.

7.3 Thermal Specifications

The board is specified to operate in an environmental temperature range from 0°C to +60°C (extended temperature on request). Maximum die temperature is 100°C. To keep the processor under this threshold an appropriate cooling solution needs to be applied. This solution has to take typical and maximum power consumption into account. The maximum power consumption may be twice as high and should be used as a basis for the cooling concept. Additional controllers may also affect the cooling concept. The power consumption of such components may be comparable to the consumption of the processor.

The board design includes thermal solution mounting points that will provide the best possible thermal interface between die and solution. Since we take thermal solutions seriously we have several advanced, aggressive cooling solutions in our product portfolio. Please contact your sales representative to order or discuss your thermal solution needs.



CAUTION

Do not exceed the maximum Die temperature!

The end customer has the responsibility to ensure that the die temperature of the processor does not exceed 100°C. Permanent overheating may destroy the board!

In case the temperature exceeds 100°C the environmental temperature must be reduced. Under certain circumstances sufficient air circulation must be provided.

8 Support and Service

Beckhoff and their partners around the world offer comprehensive support and service, making available fast and competent assistance with all questions related to Beckhoff products and system solutions.

8.1 Beckhoff's Branch Offices and Representatives

Please contact your Beckhoff branch office or representative for local support and service on Beckhoff products.

The addresses of Beckhoff's branch offices and representatives around the world can be found on her internet pages: <http://www.beckhoff.com>

You will also find further documentation for Beckhoff components there.

8.2 Beckhoff Headquarters

Beckhoff Automation GmbH & Co. KG
Eiserstr. 5
33415 Verl
Germany

phone: +49(0)5246/963-0
fax: +49(0)5246/963-198
e-mail: info@beckhoff.com
web: www.beckhoff.com

8.2.1 Beckhoff Support

Support offers you comprehensive technical assistance, helping you not only with the application of individual Beckhoff products, but also with other, wide-ranging services:

- support
- design, programming and commissioning of complex automation systems
- and extensive training programs for Beckhoff system components

hotline: +49(0)5246/963-157
fax: +49(0)5246/963-9157
e-mail: support@beckhoff.com

8.2.2 Beckhoff Service

The Beckhoff Service Center supports you in all matters of after-sales service:

- on-site service
- repair service
- spare parts service
- hotline service

hotline: +49(0)5246/963-460
fax: +49(0)5246/963-479
e-mail: service@beckhoff.com

I Annex: Post-Codes

During boot, the BIOS generates a sequence of status codes (so-called "POST codes"), which can be viewed using a special output device (POST code card). The meaning of these codes is described in the document "Aptio™ 4.x Status Codes" by American Megatrends®, which can be downloaded from their website <http://www.ami.com>. The following additional OEM POST codes are generated:

Code	Description
87h	BIOS-API started
88h	PCA9535 started
89h	PWRCTRL-Firmware started

II Annex: Resources

IO Range

The used resources depend on setup settings.

The given values are ranges, which are fixed by AT compatibility. Other IO ranges are used, which are dynamically adjusted by Plug & Play BIOS while booting.

Address	Function
0-FF	Reserved IO area of the board
170-17F	
1F0-1F7	
278-27F	
2E8-2EF	COM4
2F8-2FF	COM2
370-377	
378-37F	
3BC-3BF	
3E8-3EF	COM3
3F0-3F7	
3F8-3FF	COM1

Memory Range

The used resources depend on setup settings.

If the entire range is clogged through option ROMs, these functions do not work anymore.

Address	Function
A0000-BFFFF	VGA RAM
C0000-CFFFF	VGA BIOS
D0000-E7FFF	AHCI BIOS / RAID / PXE (if available)
E8000-FFFFFF	System BIOS

Interrupt

The used resources depend on setup settings.

The listed interrupts and their use are given through AT compatibility.

If interrupts must exclusively be available on the ISA side, they have to be reserved through the BIOS setup. The exclusivity is not given and not possible on the PCI side.

Address	Function
IRQ0	Timer
IRQ1	PS/2 Keyboard
IRQ2 (9)	
IRQ3	COM1
IRQ4	COM2
IRQ5	
IRQ6	
IRQ7	
IRQ8	RTC
IRQ9	
IRQ10	COM4
IRQ11	COM3
IRQ12	PS/2 Mouse
IRQ13	FPU
IRQ14	

Address	Function
IRQ15	

PCI Devices

All listed PCI devices exist on the board. Some PCI devices or functions of devices may be disabled in the BIOS setup. Once a device is disabled other devices may get PCI bus numbers different from the ones listed in the table.

AD	INTA	REQ	Bus	Dev.	Fct.	Controller / Slot
	-	-	0	0	0	Host Bridge ID0C00h
	A	-	0	2	0	VGA Graphics ID0402h
	A	-	0	20	0	USB xHCI QM87 ID8C31h
	A	-	0	22	0	Intel® ME Interface#1 QM87 ID8C3Ah
	A	-	0	22	1	Intel® ME Interface#2 QM87 ID8C3Bh
	A	-	0	22	2	IDE-R QM87 ID8C3Ch
	A	-	0	22	3	KT QM87 ID8C3Dh
	A	-	0	25	0	LAN QM87 ID153A
	A	-	0	26	0	USB EHCI Controller #2 QM87 ID8C2Dh
	A	-	0	27	0	HDA Controller QM87 ID8C20h
	A	-	0	28	0	PCI Express Port 1 QM87 ID8C10h
	B	-	0	28	1	[PCI Express Port 2 QM87 ID8C12h]
	C	-	0	28	2	[PCI Express Port 3 QM87 ID8C14h]
	D	-	0	28	3	[PCI Express Port 4 QM87 ID8C16h]
	A	-	0	28	4	PCI Express Port 5 QM87 ID8C18h
	B	-	0	28	5	PCI Express Port 6 QM87 ID8C1Ah
	C	-	0	28	6	PCI Express Port 7 QM87 ID8C1Ch
	D	-	0	28	7	[PCI Express Port 8 QM87 ID8C1Eh]
	A	-	0	29	0	USB EHCI Controller #1 QM87 ID8C26h
	-	-	0	31	0	ISA Bridge QM87 ID8C4Fh
	B	-	0	31	2	SATA Interface #1 QM87 ID8C01h
	B	-	0	31	3	SMBus Interface QM87 ID8C22h
	B	-	0	31	5	SATA Interface #2 QM87 ID8C09h
	A	-	m	0	0	LAN i210 ID1533
	A	-	n	0	0	PCIe-to-PCI Bridge IDE111h
20	A	0	o	4	0	mPCI Slot 1

SMB Devices

The following table contains all reserved SM-Bus device addresses in 8-bit notation. Note that external devices must not use any of these addresses even if the component mentioned in the table is not present on the motherboard.

Address	Function
10-11	Standard slave address
40-41	GPIO
70-73	POST code output
88-89	BIOS-defined slave address
A0-A1	DIMM 1
A2-A3	DIMM 2
A4-AF	BIOS internal
B0-BF	BIOS internal